

RAURIKI LANE

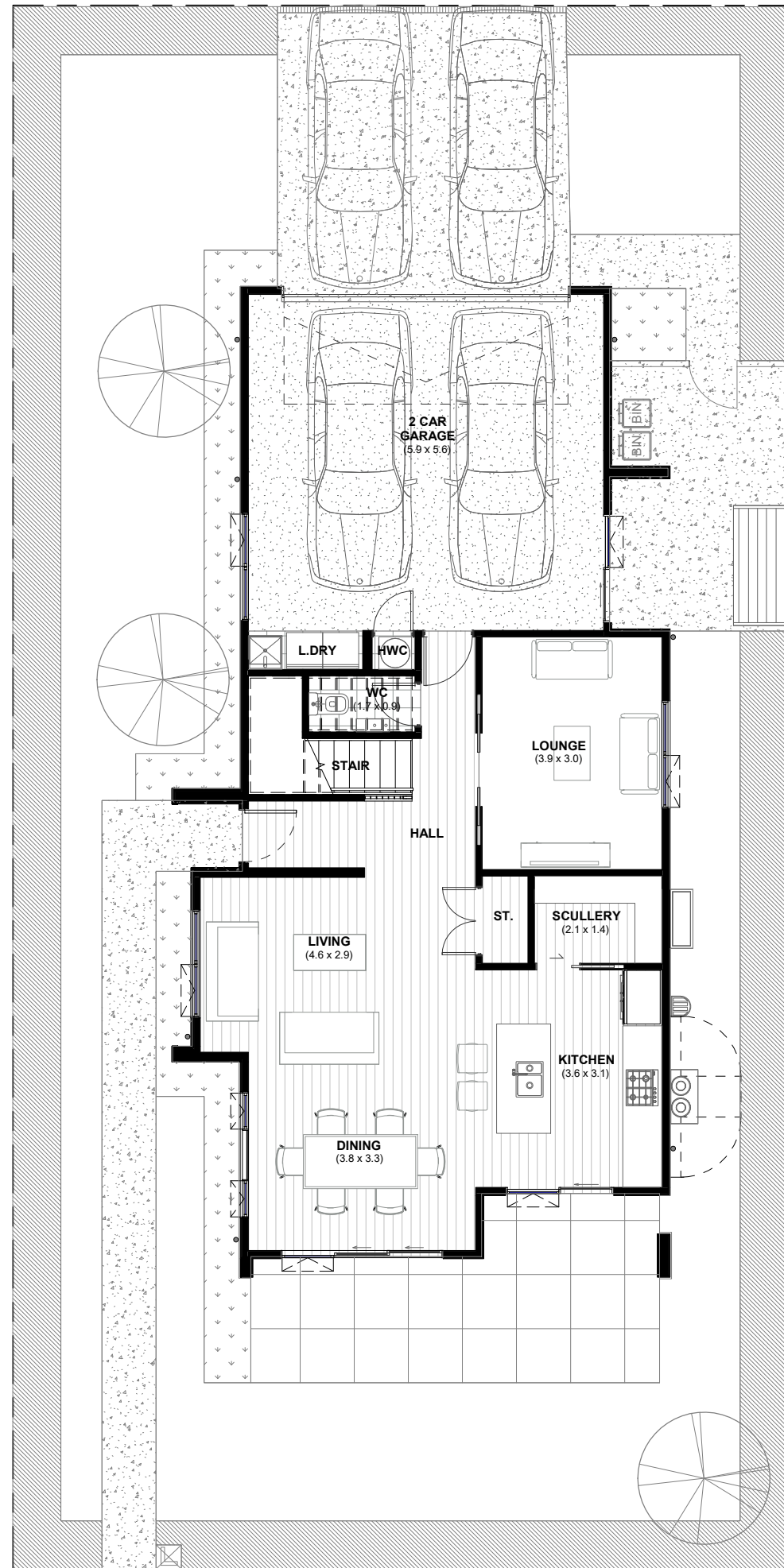

PARK ESTATE ROAD

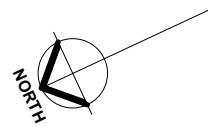

LOT 64 - HOUSE TYPE AA

216 PARK ESTATE ROAD, HINGAIA

First Floor Area - 93m²
Ground Floor Area - 108m²
Overall Area - 201m²
Site Area - 335m²



PLANS MAY BE SUBJECT TO CHANGE.
 FLOOR AREAS INDICATED IS APPROXIMATE ONLY

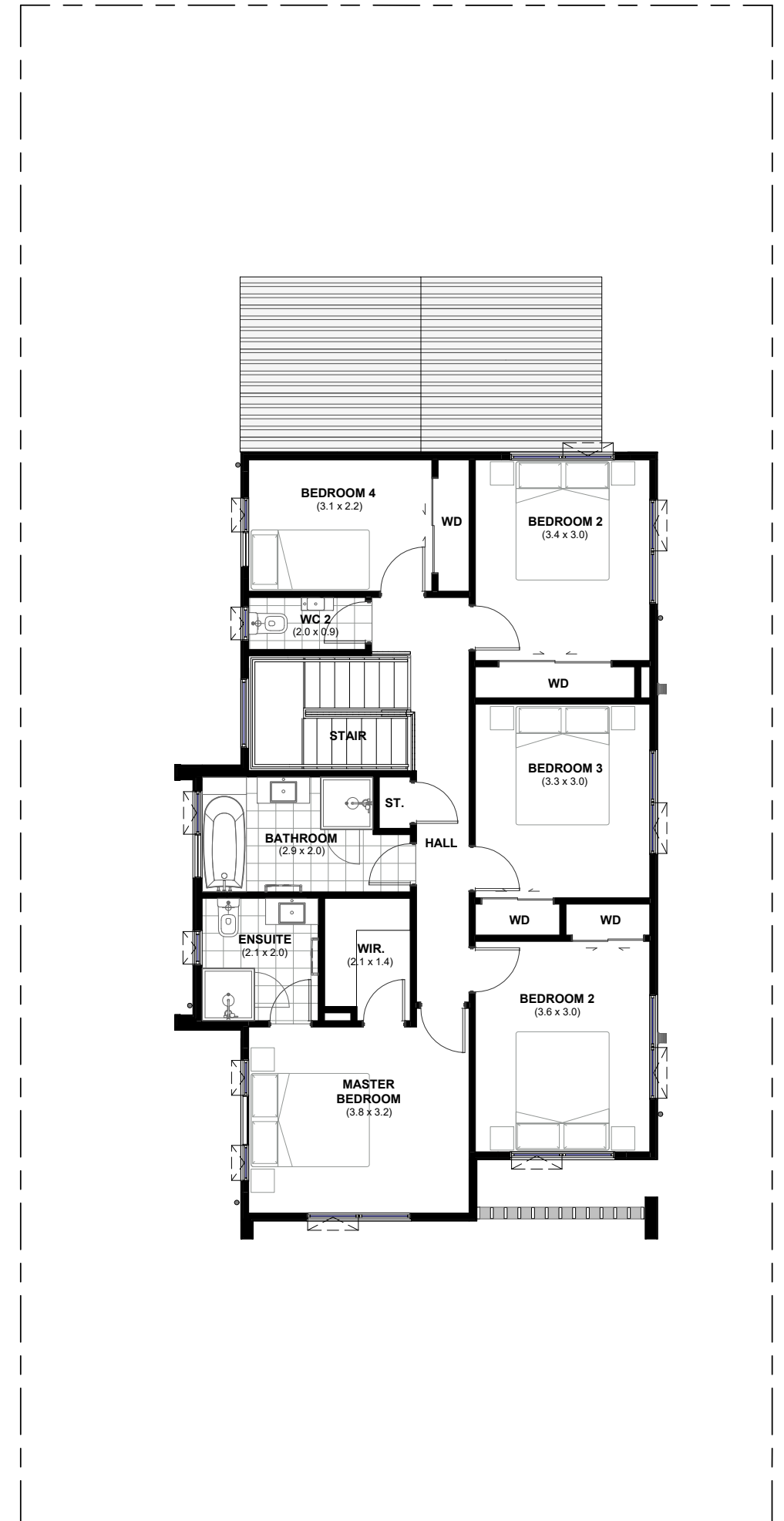

RAURIKI LANE

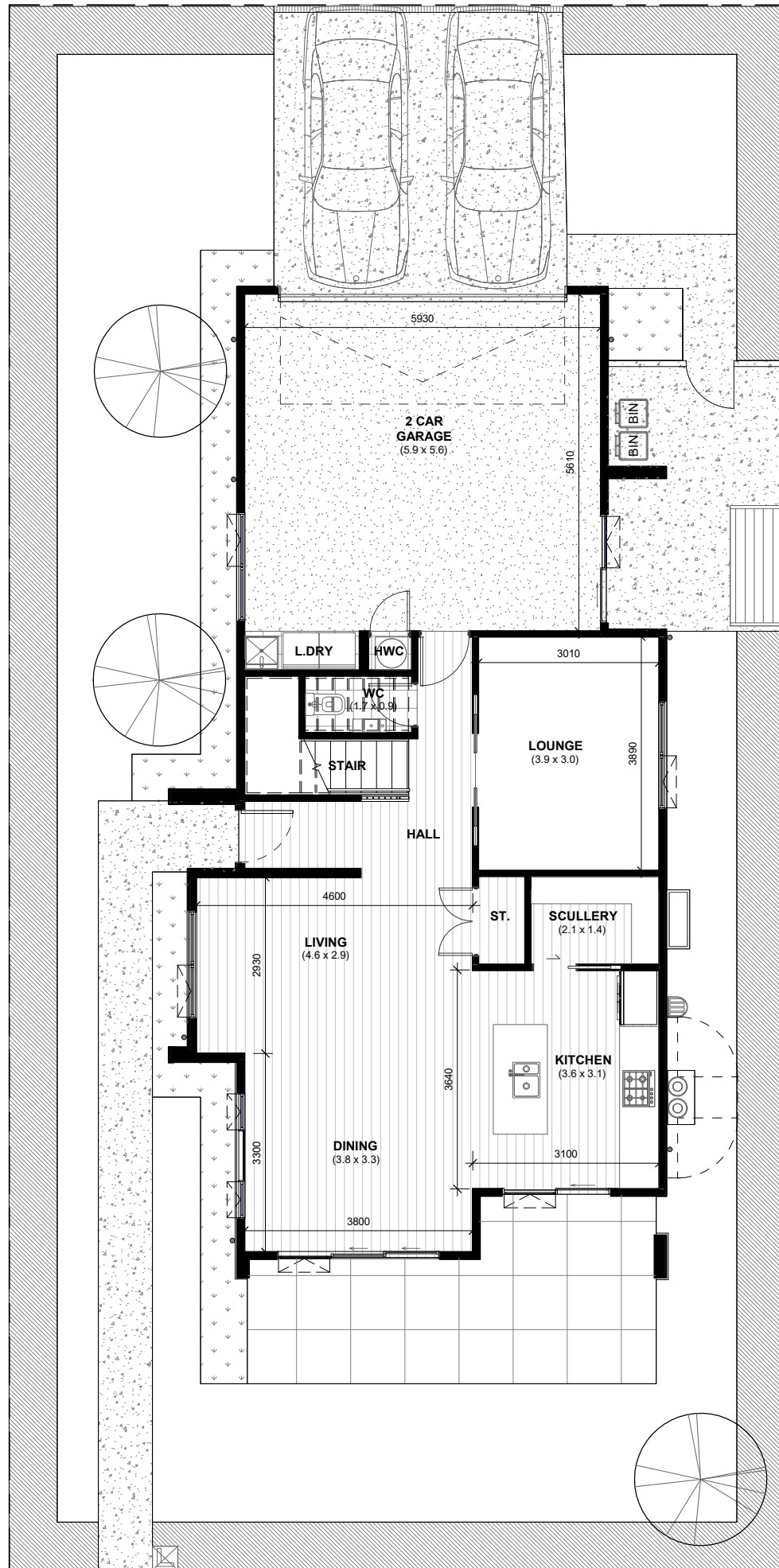

PARK ESTATE ROAD

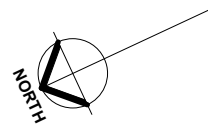

LOT 64 - HOUSE TYPE AA

216 PARK ESTATE ROAD, HINGAIA

First Floor Area - 93m²
Ground Floor Area - 108m²
Overall Area - 201m²
Site Area - 335m²

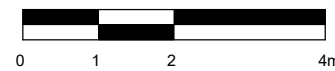

PLANS MAY BE SUBJECT TO CHANGE.
 FLOOR AREAS INDICATED IS APPROXIMATE ONLY



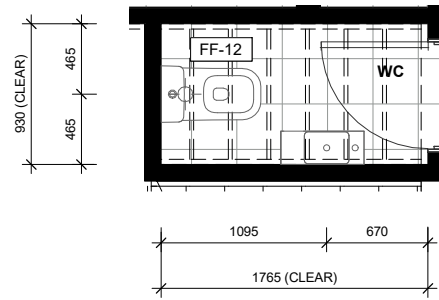

LOT 64 - GROUND FLOOR WC LAYOUT

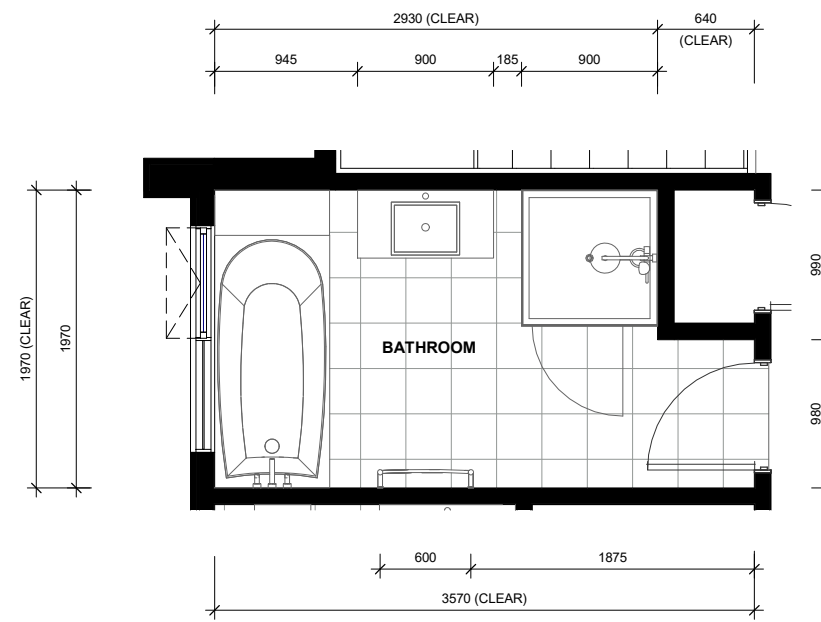

LOT 64 - FIRST FLOOR BATHROOM LAYOUT

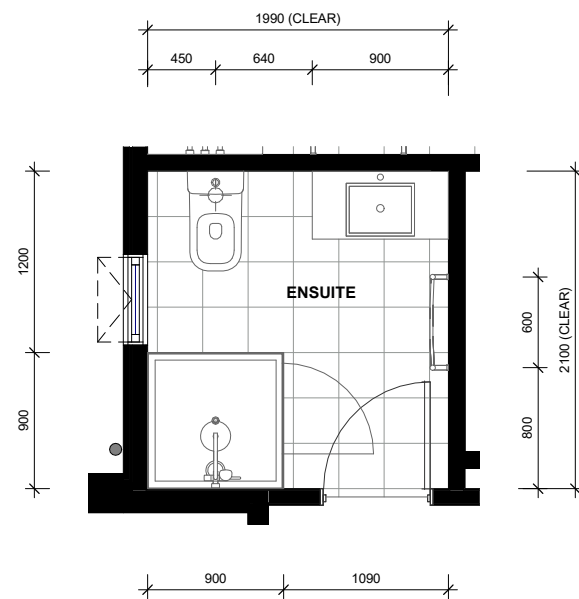

LOT 64 - FIRST FLOOR ENSUITE LAYOUT

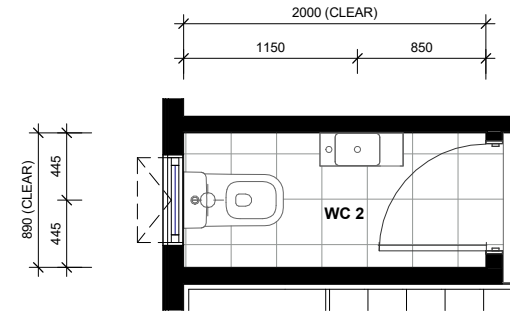

LOT 64 - FIRST FLOOR WC2 LAYOUT

LOT 64 - HOUSE TYPE AA

216 PARK ESTATE ROAD, HINGAIA

PLANS MAY BE SUBJECT TO CHANGE.
FLOOR AREAS INDICATED IS APPROXIMATE ONLY

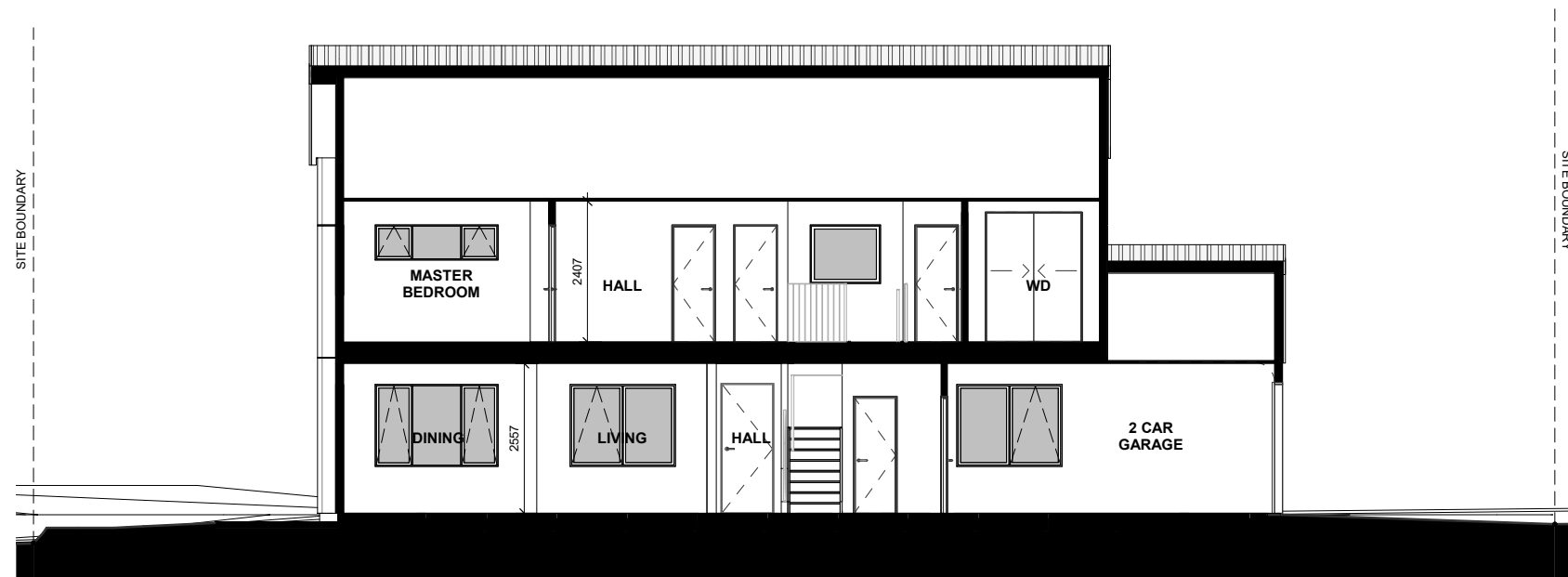

LOT 64 - SECTION A-A

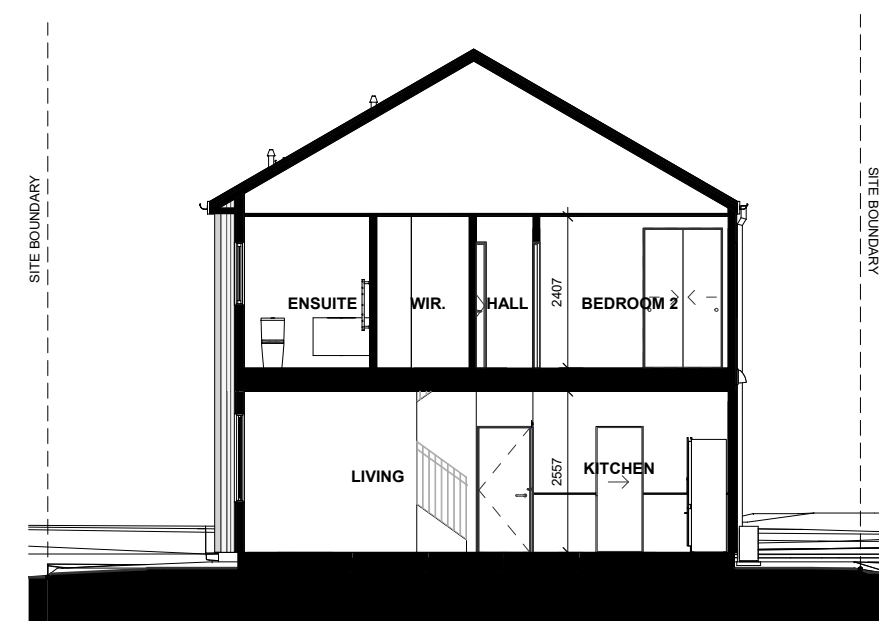

LOT 64 - SECTION C-C



LOT 64 - SECTION B-B

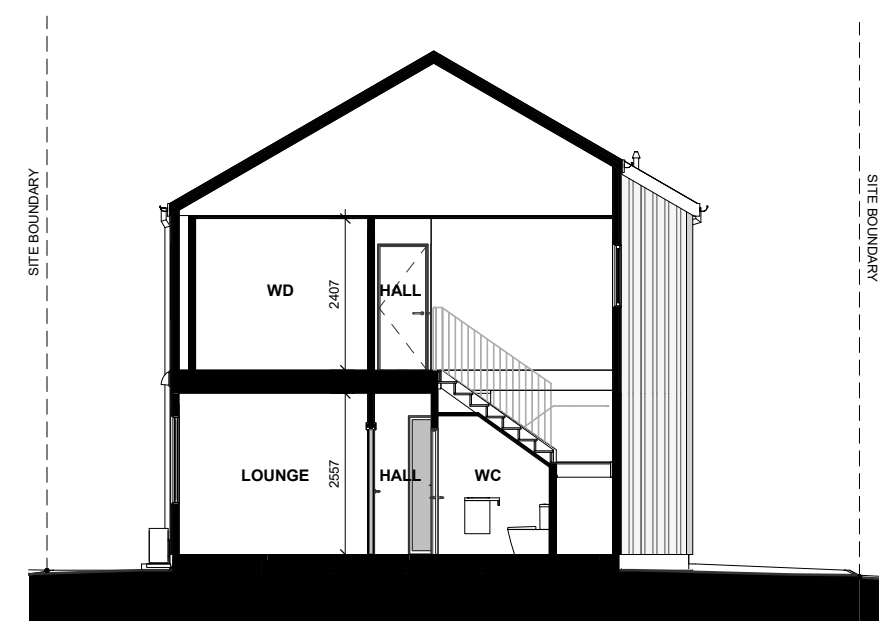

LOT 64 - SECTION D-D

LOT 64 - HOUSE TYPE AA

216 PARK ESTATE ROAD, HINGAIA

PLANS MAY BE SUBJECT TO CHANGE.
FLOOR AREAS INDICATED IS APPROXIMATE ONLY

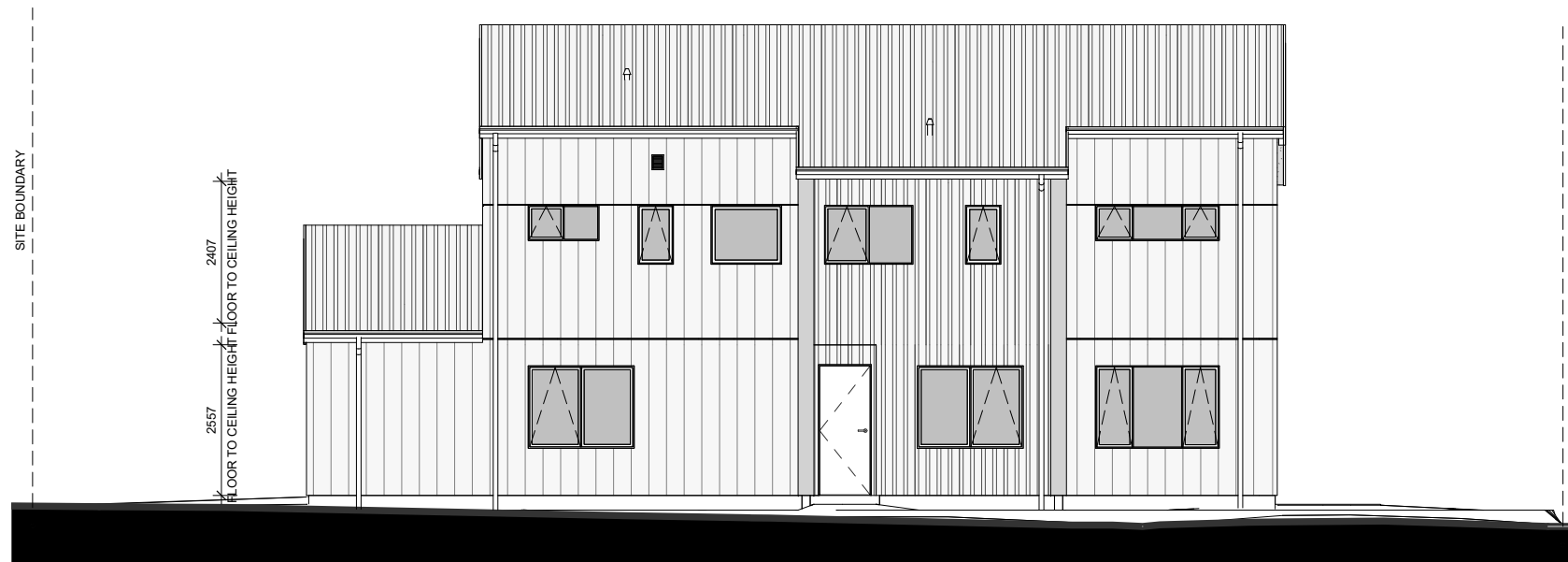

LOT 64 - EAST ELEVATION



LOT 64 - NORTH ELEVATION



LOT 64 - WEST ELEVATION

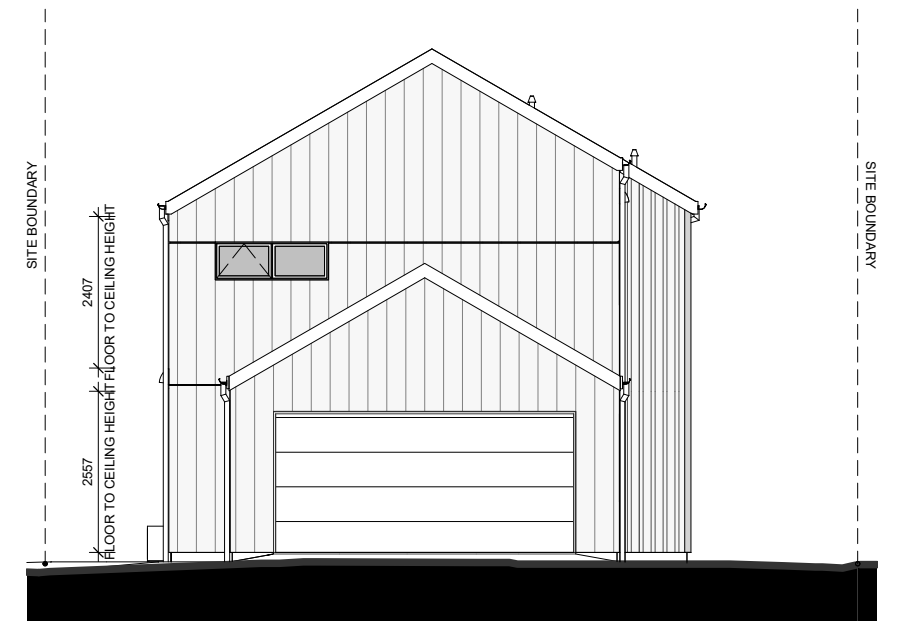

LOT 64 - SOUTH ELEVATION

LOT 64 - HOUSE TYPE AA

216 PARK ESTATE ROAD, HINGAIA

PLANS MAY BE SUBJECT TO CHANGE.
FLOOR AREAS INDICATED IS APPROXIMATE ONLY