

LOT 80
GROUND FLOOR PLAN
101 KAKATI DRIVE, MANUREWA
Floor Area - 168m²
Site Area - 269m²
Ground Floor - 87m²
First Floor - 81m²

LOT 77
GROUND FLOOR PLAN
107 KAKATI DRIVE, MANUREWA
Floor Area - 168m²
Site Area - 278m²
Ground Floor - 87m²
First Floor - 81m²

LOT 79
GROUND FLOOR PLAN
103 KAKATI DRIVE, MANUREWA
Floor Area - 156m²
Site Area - 174m²
Ground Floor - 78m²
First Floor - 78m²

LOT 78
GROUND FLOOR PLAN
105 KAKATI DRIVE, MANUREWA
Floor Area - 156m²
Site Area - 177m²
Ground Floor - 78m²
First Floor - 78m²

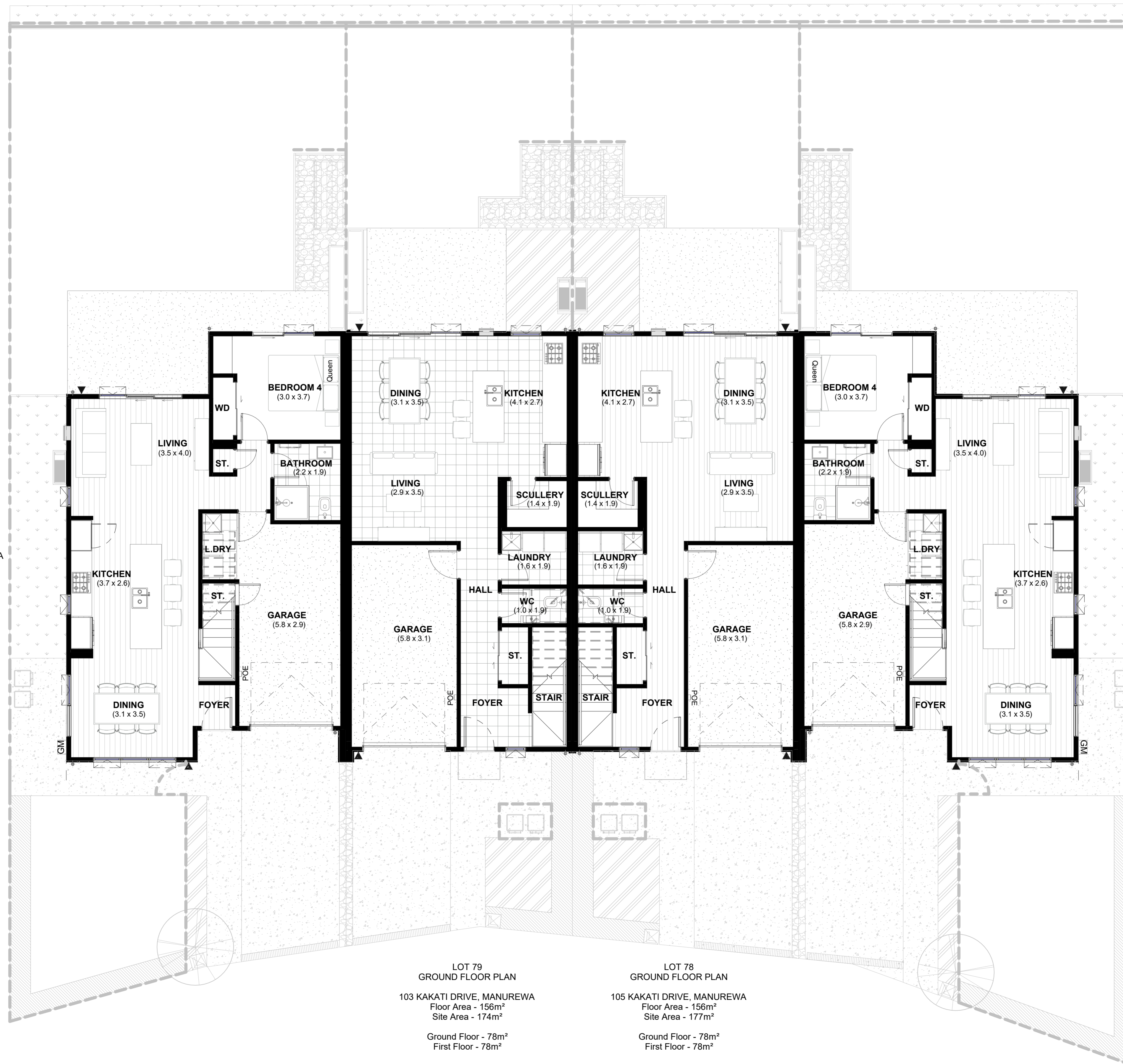

PLANS MAY BE SUBJECT TO CHANGE.
FLOOR AREAS INDICATED IS APPROXIMATE ONLY

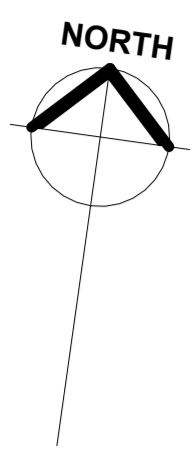

LOT 80
GROUND FLOOR PLAN
101 KAKATI DRIVE, MANUREWA
Floor Area - 168m²
Site Area - 269m²
Ground Floor - 87m²
First Floor - 81m²

LOT 77
GROUND FLOOR PLAN
107 KAKATI DRIVE, MANUREWA
Floor Area - 168m²
Site Area - 278m²
Ground Floor - 87m²
First Floor - 81m²

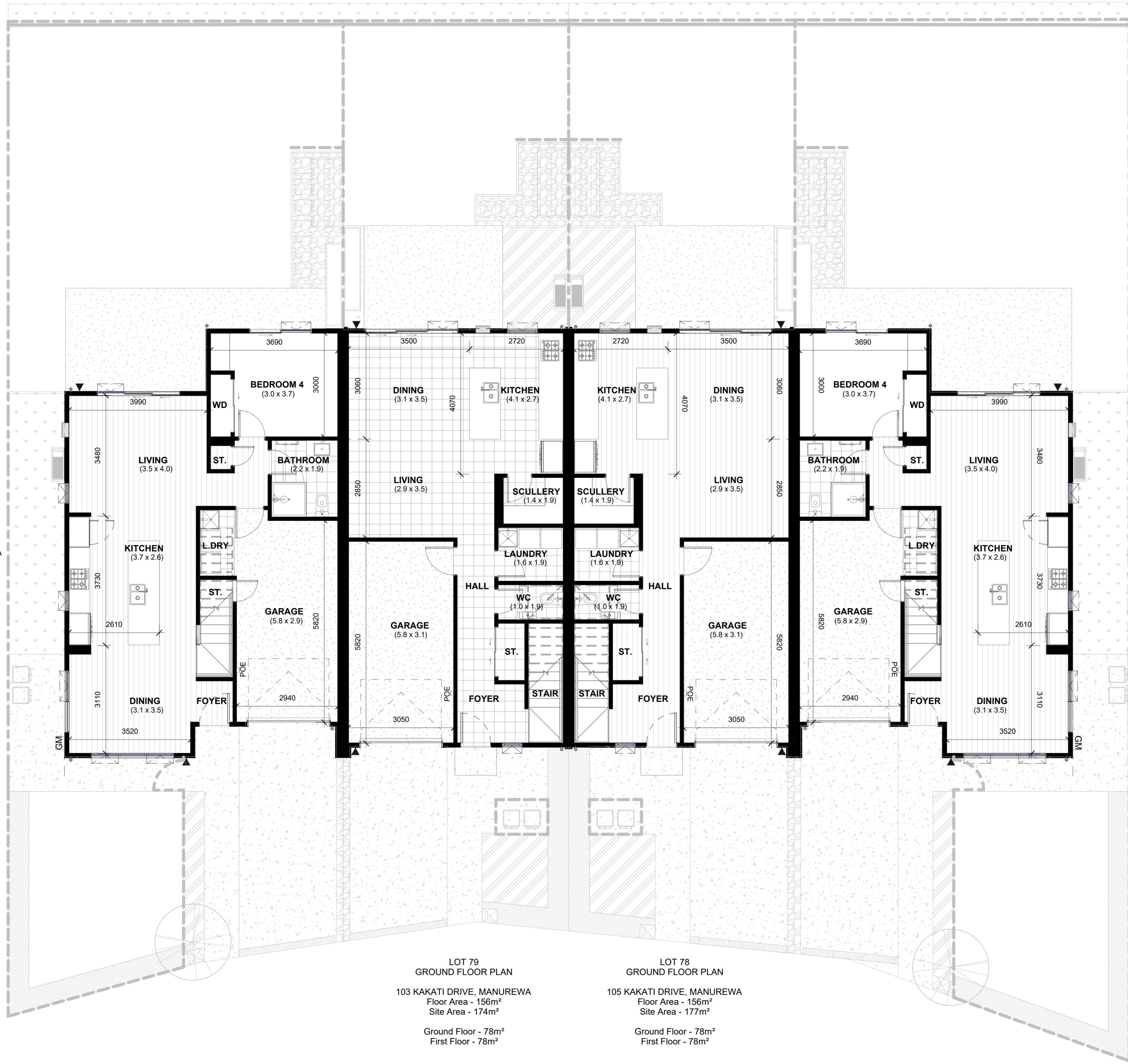

LOT 79
GROUND FLOOR PLAN
103 KAKATI DRIVE, MANUREWA
Floor Area - 156m²
Site Area - 174m²
Ground Floor - 78m²
First Floor - 78m²

LOT 78
GROUND FLOOR PLAN
105 KAKATI DRIVE, MANUREWA
Floor Area - 156m²
Site Area - 177m²
Ground Floor - 78m²
First Floor - 78m²

PLANS MAY BE SUBJECT TO CHANGE.
FLOOR AREAS INDICATED IS APPROXIMATE ONLY

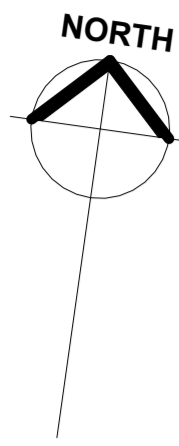

LOT 80
FIRST FLOOR PLAN
101 KAKATI DRIVE, MANUREWA
Floor Area - 168m²
Site Area - 269m²
Ground Floor - 87m²
First Floor - 81m²

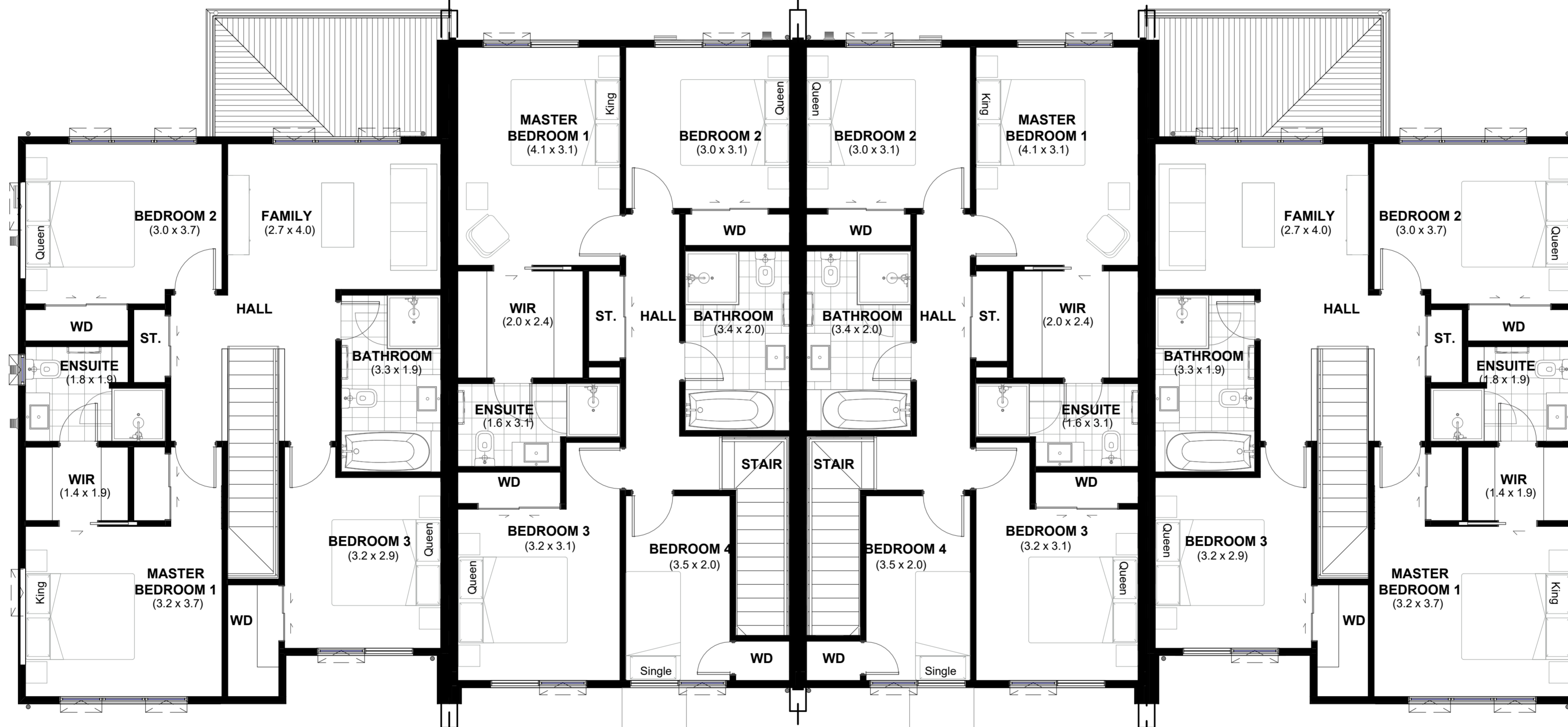

LOT 77
FIRST FLOOR PLAN
107 KAKATI DRIVE, MANUREWA
Floor Area - 168m²
Site Area - 278m²
Ground Floor - 87m²
First Floor - 81m²

LOT 79
FIRST FLOOR PLAN
103 KAKATI DRIVE, MANUREWA
Floor Area - 156m²
Site Area - 174m²
Ground Floor - 78m²
First Floor - 78m²

LOT 78
FIRST FLOOR PLAN
105 KAKATI DRIVE, MANUREWA
Floor Area - 156m²
Site Area - 177m²
Ground Floor - 78m²
First Floor - 78m²

PLANS MAY BE SUBJECT TO CHANGE.
FLOOR AREAS INDICATED IS APPROXIMATE ONLY

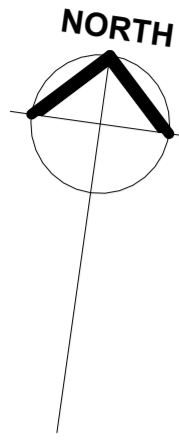

LOT 80
FIRST FLOOR PLAN
101 KAKATI DRIVE, MANUREWA
Floor Area - 168m²
Site Area - 269m²
Ground Floor - 87m²
First Floor - 81m²



LOT 77
FIRST FLOOR PLAN
107 KAKATI DRIVE, MANUREWA
Floor Area - 168m²
Site Area - 278m²
Ground Floor - 87m²
First Floor - 81m²

LOT 79
FIRST FLOOR PLAN
103 KAKATI DRIVE, MANUREWA
Floor Area - 156m²
Site Area - 174m²
Ground Floor - 78m²
First Floor - 78m²

LOT 78
FIRST FLOOR PLAN
105 KAKATI DRIVE, MANUREWA
Floor Area - 156m²
Site Area - 177m²
Ground Floor - 78m²
First Floor - 78m²

PLANS MAY BE SUBJECT TO CHANGE.
FLOOR AREAS INDICATED IS APPROXIMATE ONLY



OVERALL SOUTH ELEVATION

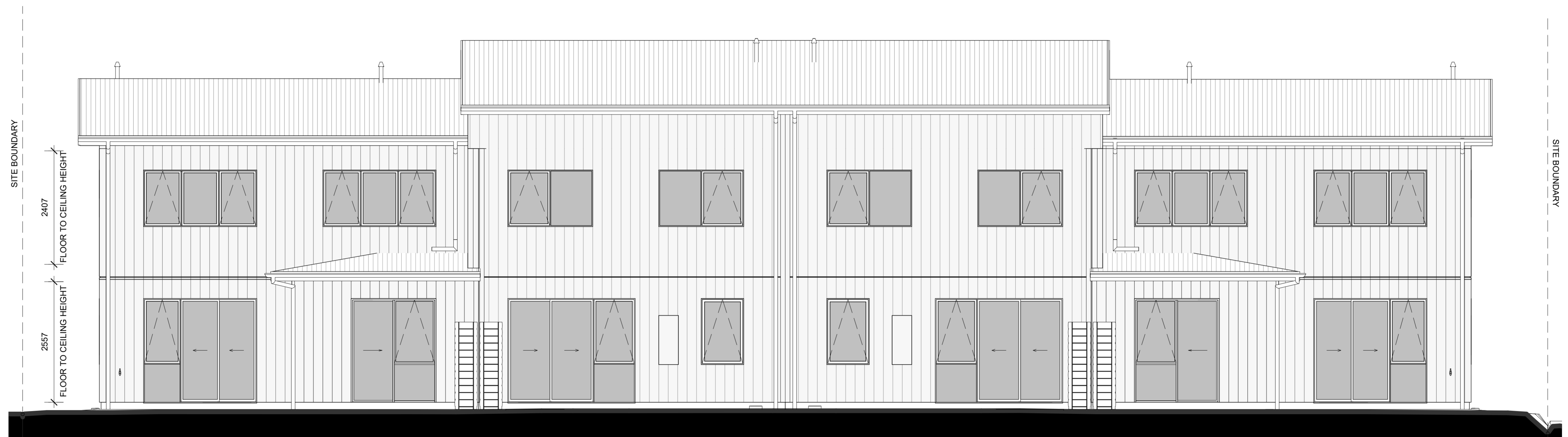

OVERALL NORTH ELEVATION

PLANS MAY BE SUBJECT TO CHANGE.
FLOOR AREAS INDICATED IS APPROXIMATE ONLY

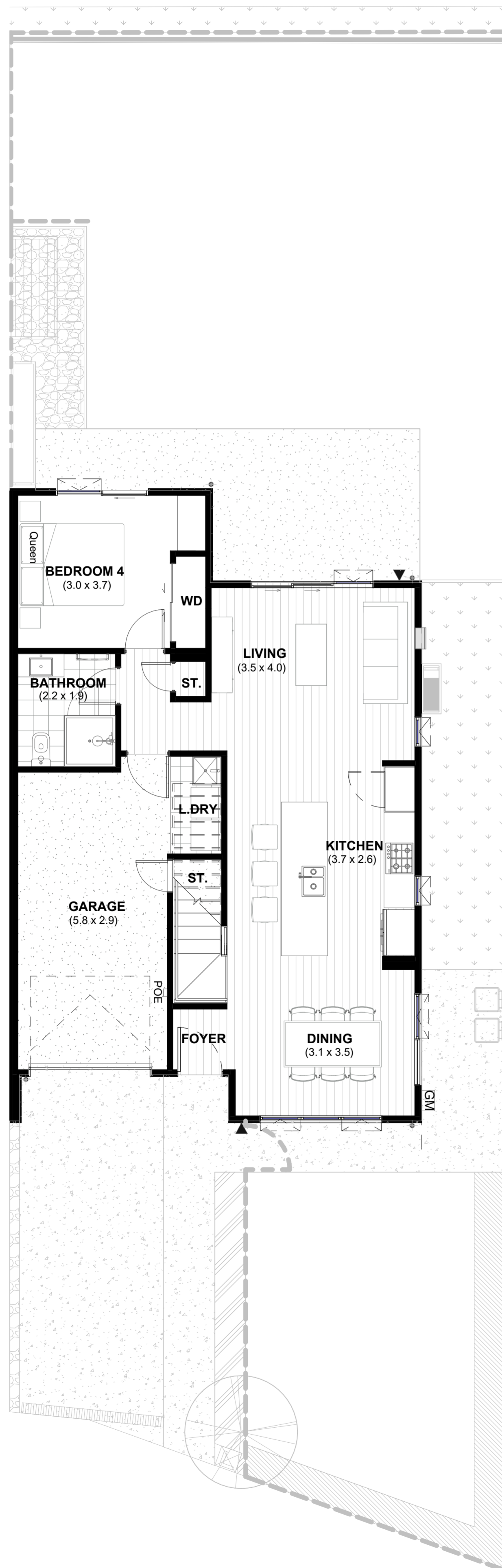

LOT 77 - GROUND FLOOR PLAN

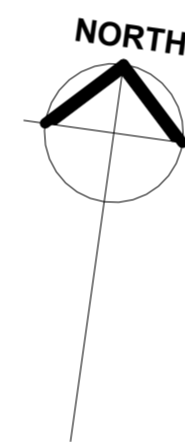

LOT 77

107 KATIKATI DRIVE, MANUREWA

First Floor Area - 81m²
Ground Floor Area - 87m²
Overall Area - 168m²
Site Area - 228m²

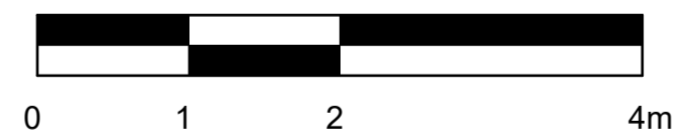

PLANS MAY BE SUBJECT TO CHANGE.
 FLOOR AREAS INDICATED IS APPROXIMATE ONLY



LOT 77 - FIRST FLOOR PLAN

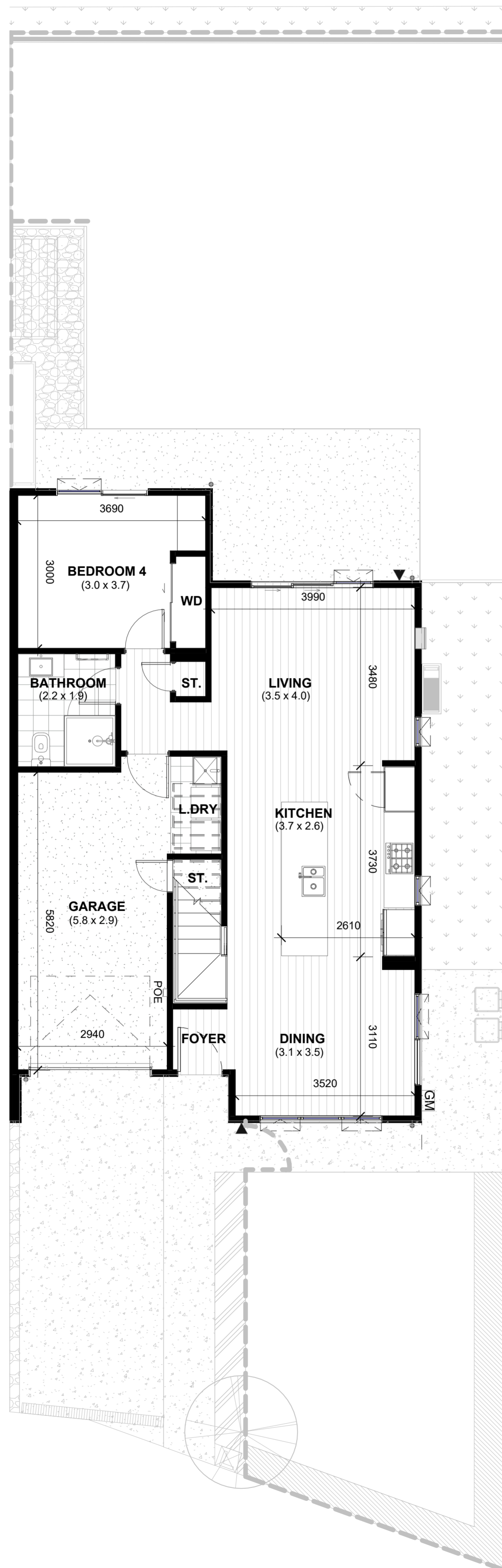

LOT 77 - GROUND FLOOR DIMENSION PLAN

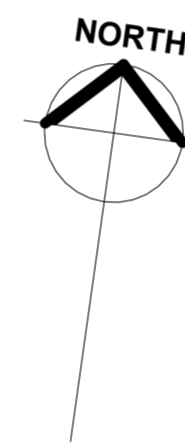

LOT 77

107 KATIKATI DRIVE, MANUREWA

First Floor Area - 81m²
Ground Floor Area - 87m²
Overall Area - 168m²
Site Area - 228m²

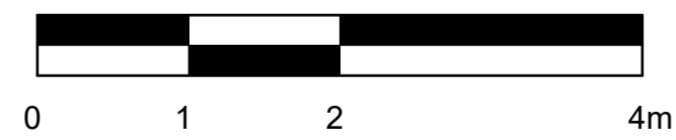

PLANS MAY BE SUBJECT TO CHANGE.
 FLOOR AREAS INDICATED IS APPROXIMATE ONLY



LOT 77 - FIRST FLOOR DIMENSION PLAN

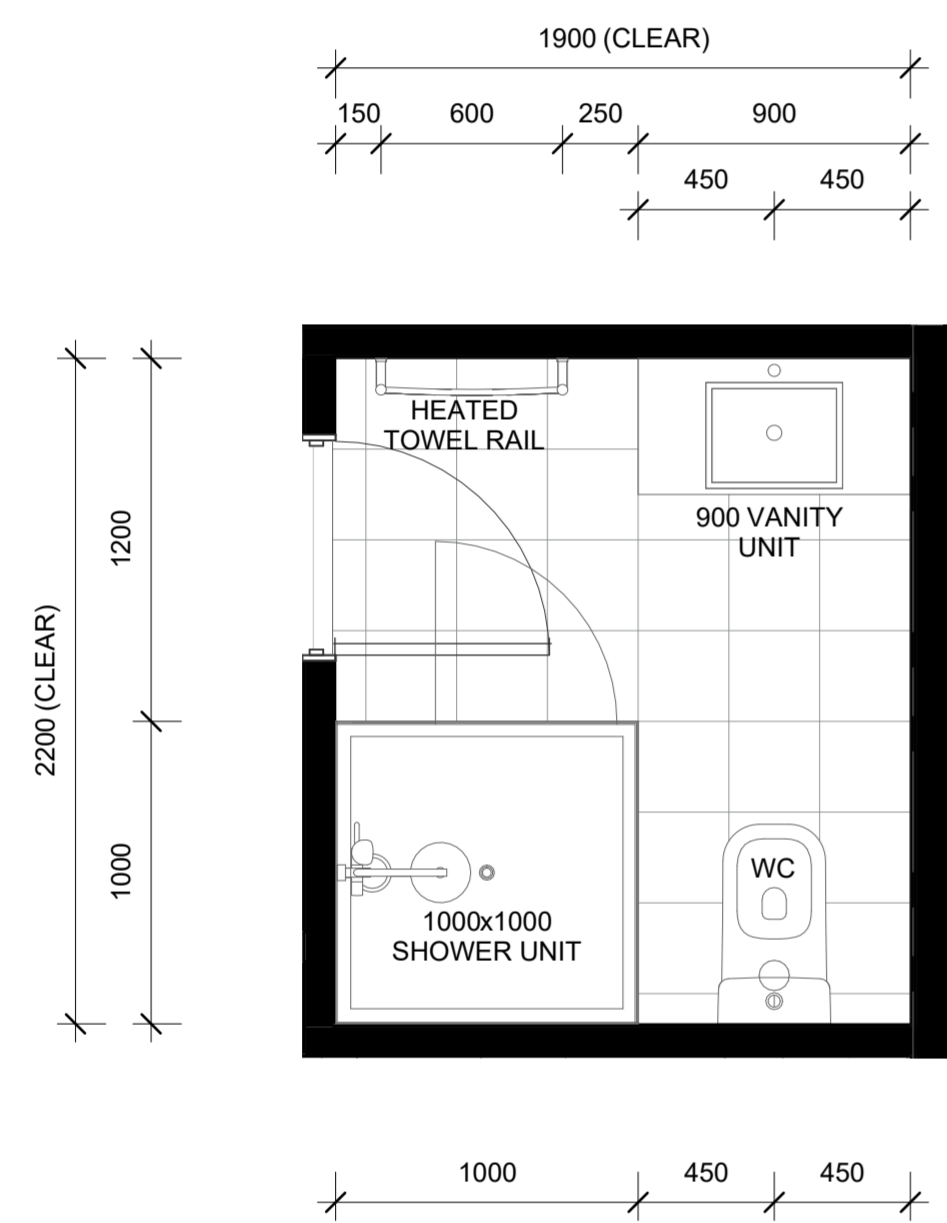

LOT 77 - GROUND FLOOR BATHROOM LAYOUT

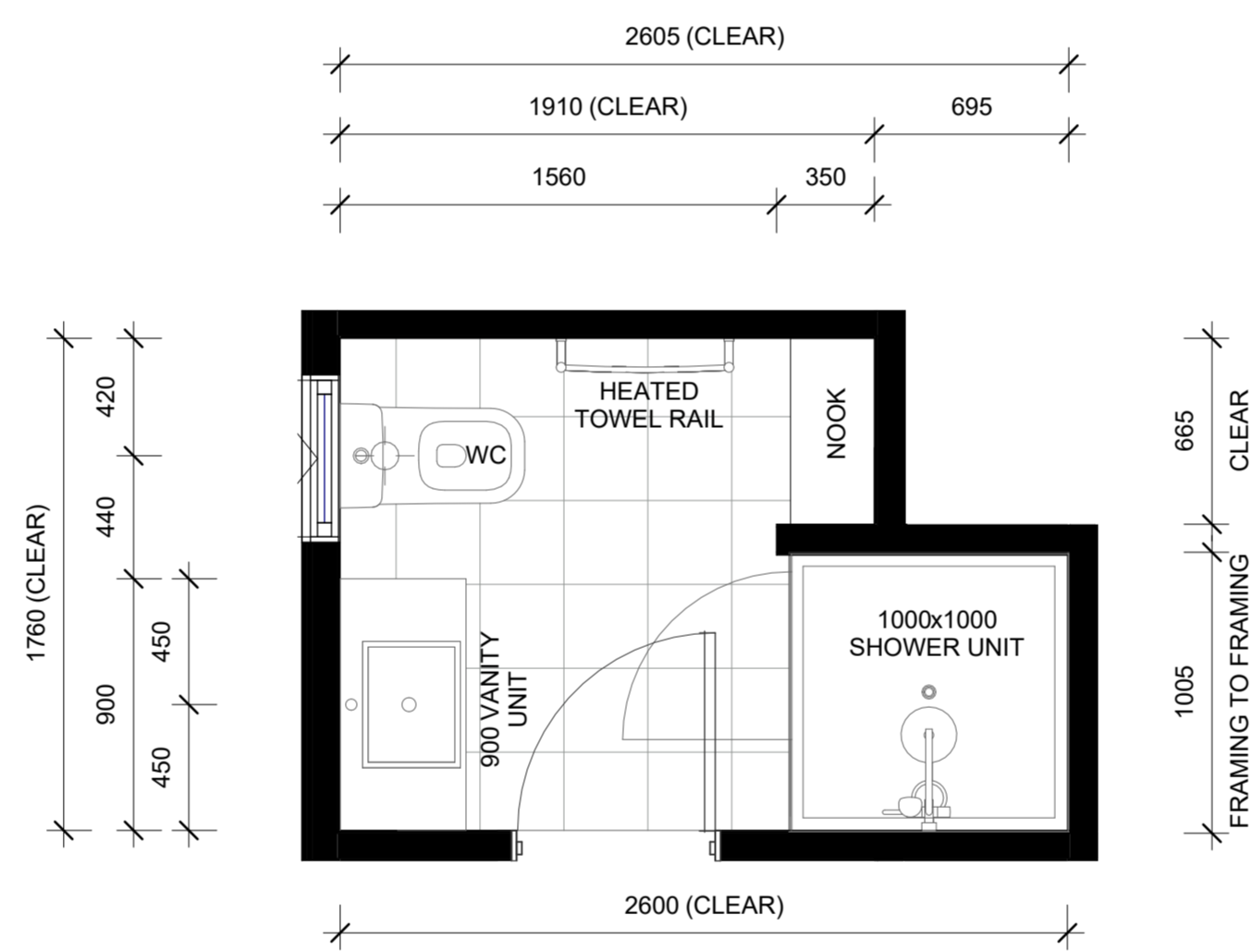

LOT 77 - FIRST FLOOR ENSUITE PLAN

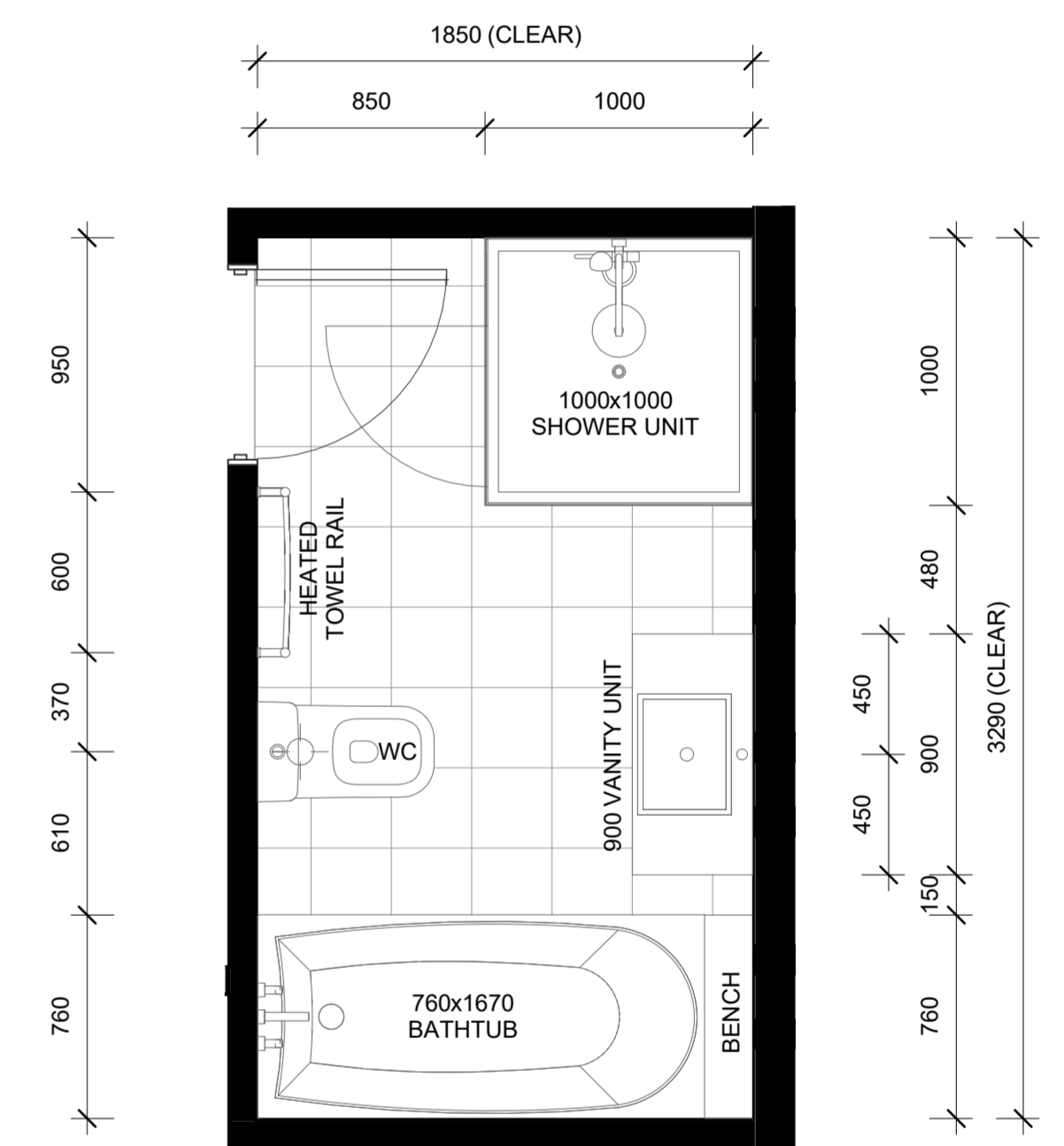

LOT 77 - FIRST FLOOR BATHROOM LAYOUT

LOT 77

107 KATIKATI DRIVE, MANUREWA

PLANS MAY BE SUBJECT TO CHANGE.
FLOOR AREAS INDICATED IS APPROXIMATE ONLY

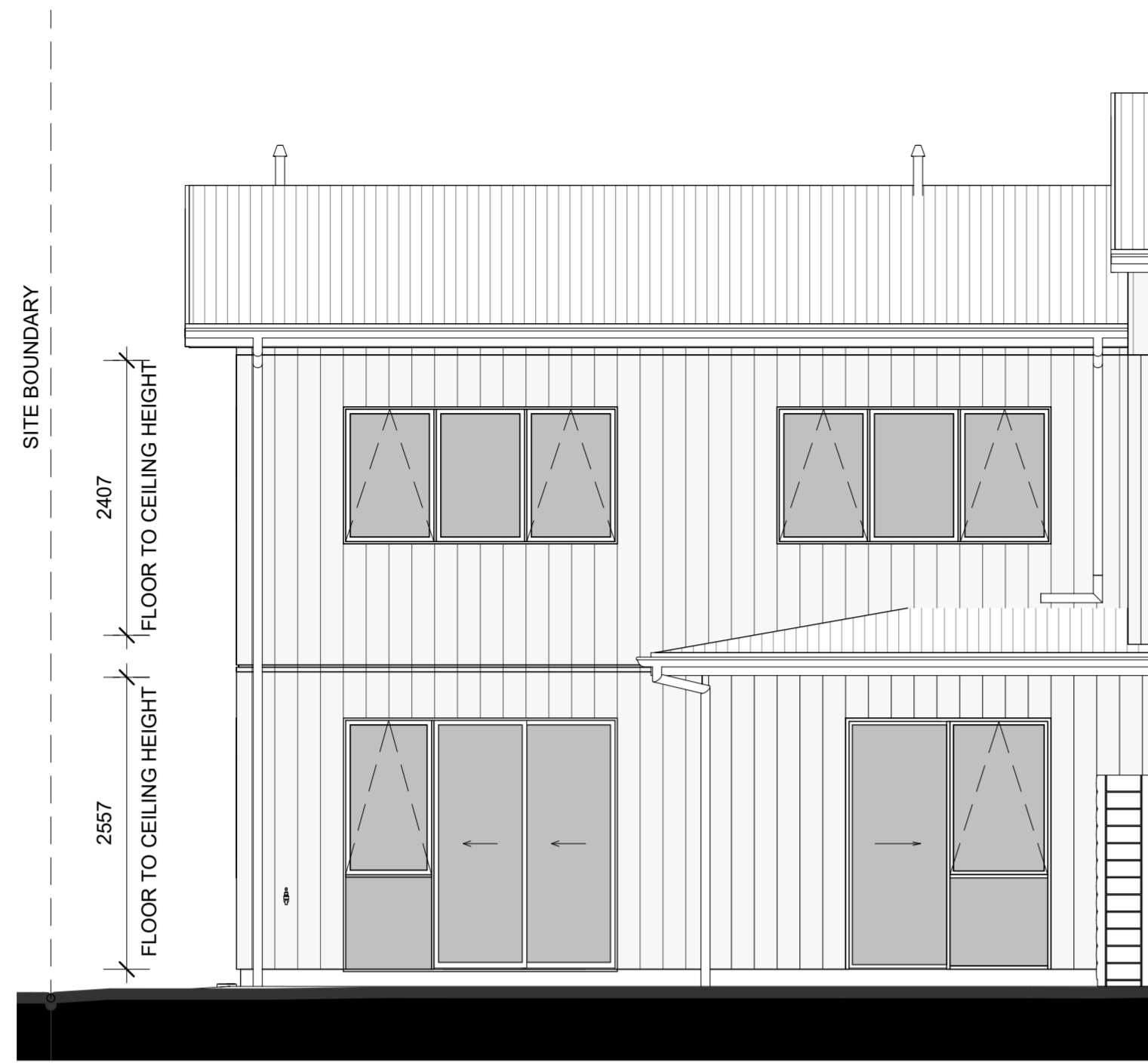

LOT 77 - NORTH ELEVATION

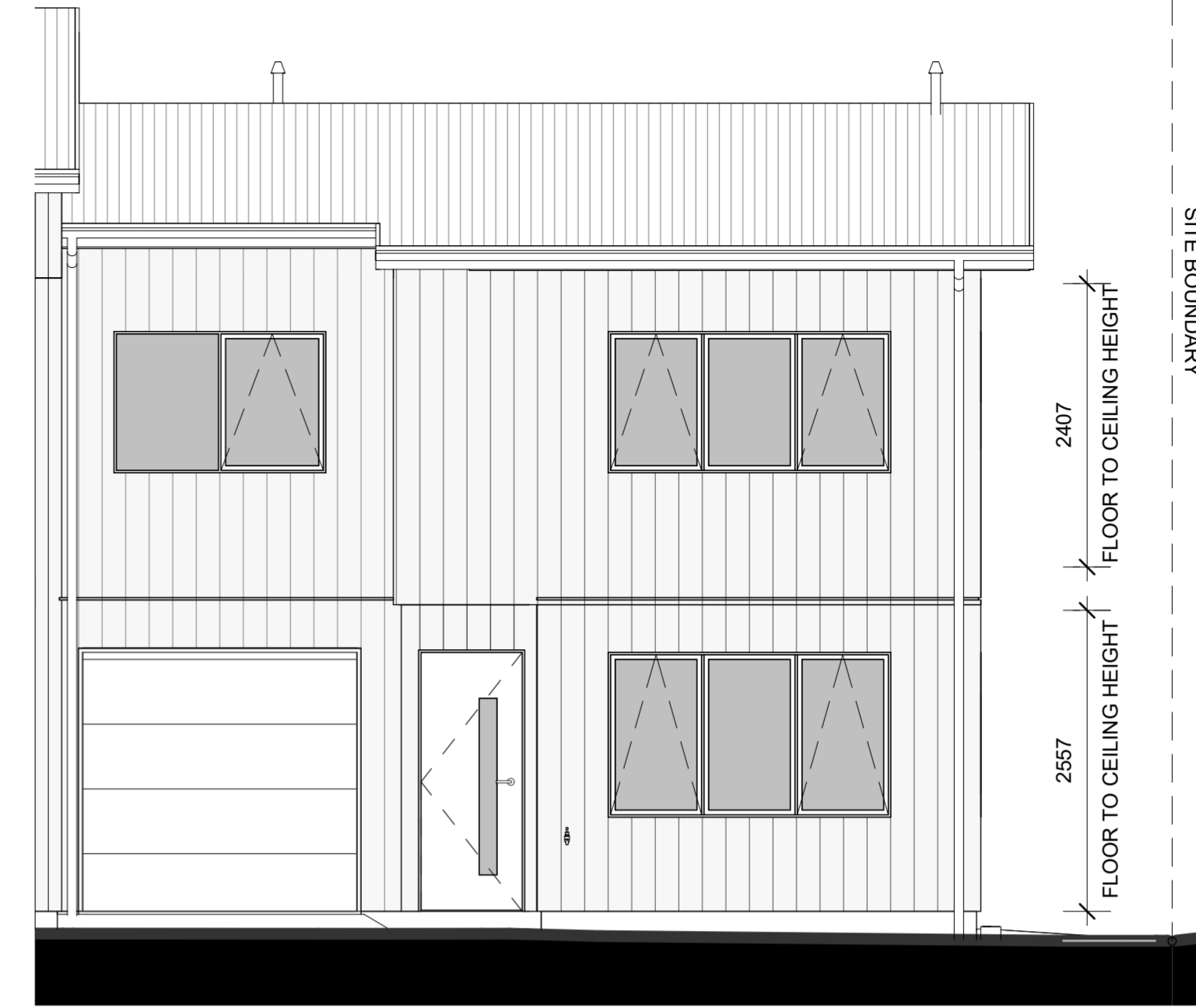

LOT 77 - SOUTH ELEVATION

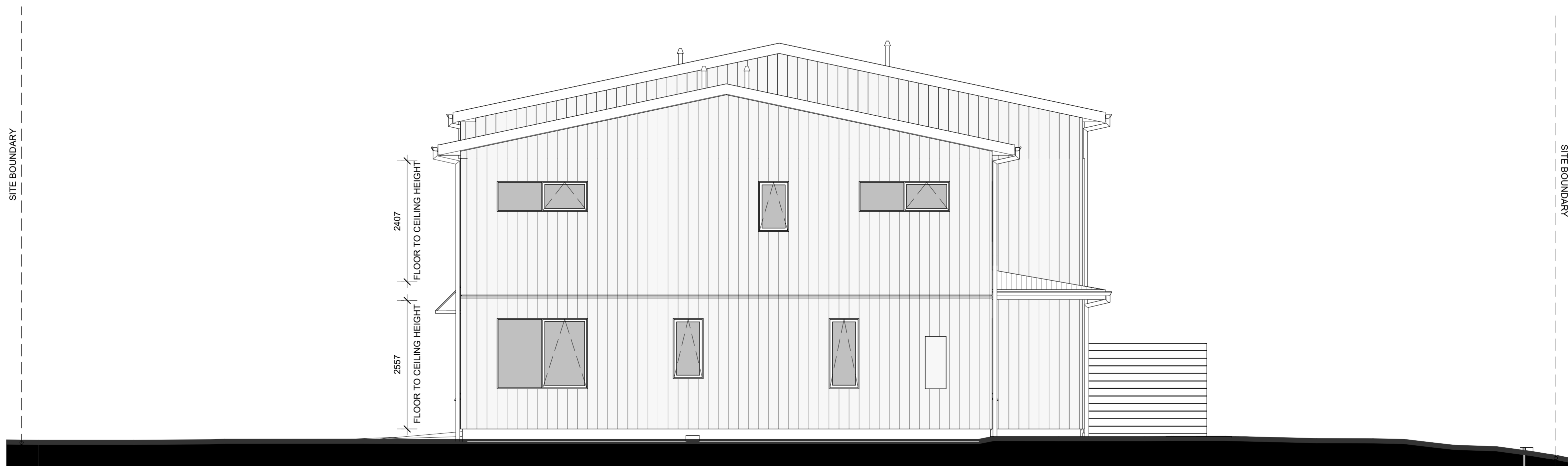

LOT 77 - EAST ELEVATION

LOT 77

107 KATIKATI DRIVE, MANUREWA

PLANS MAY BE SUBJECT TO CHANGE.
FLOOR AREAS INDICATED IS APPROXIMATE ONLY

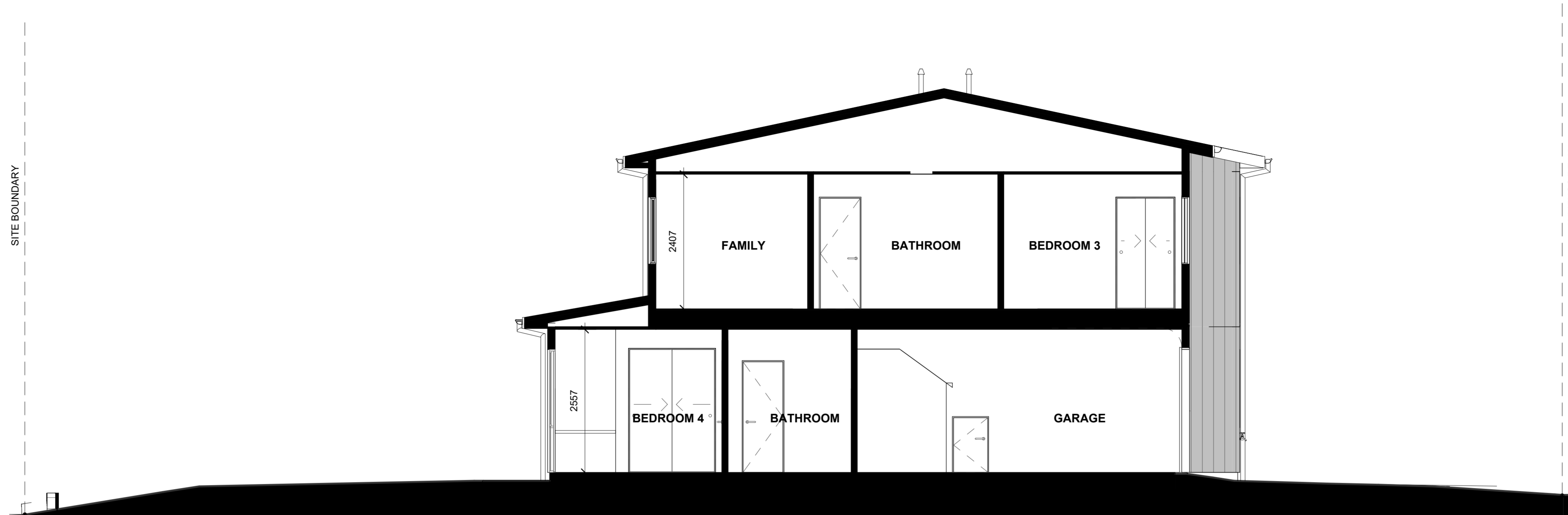

LOT 77 - SECTION A-A

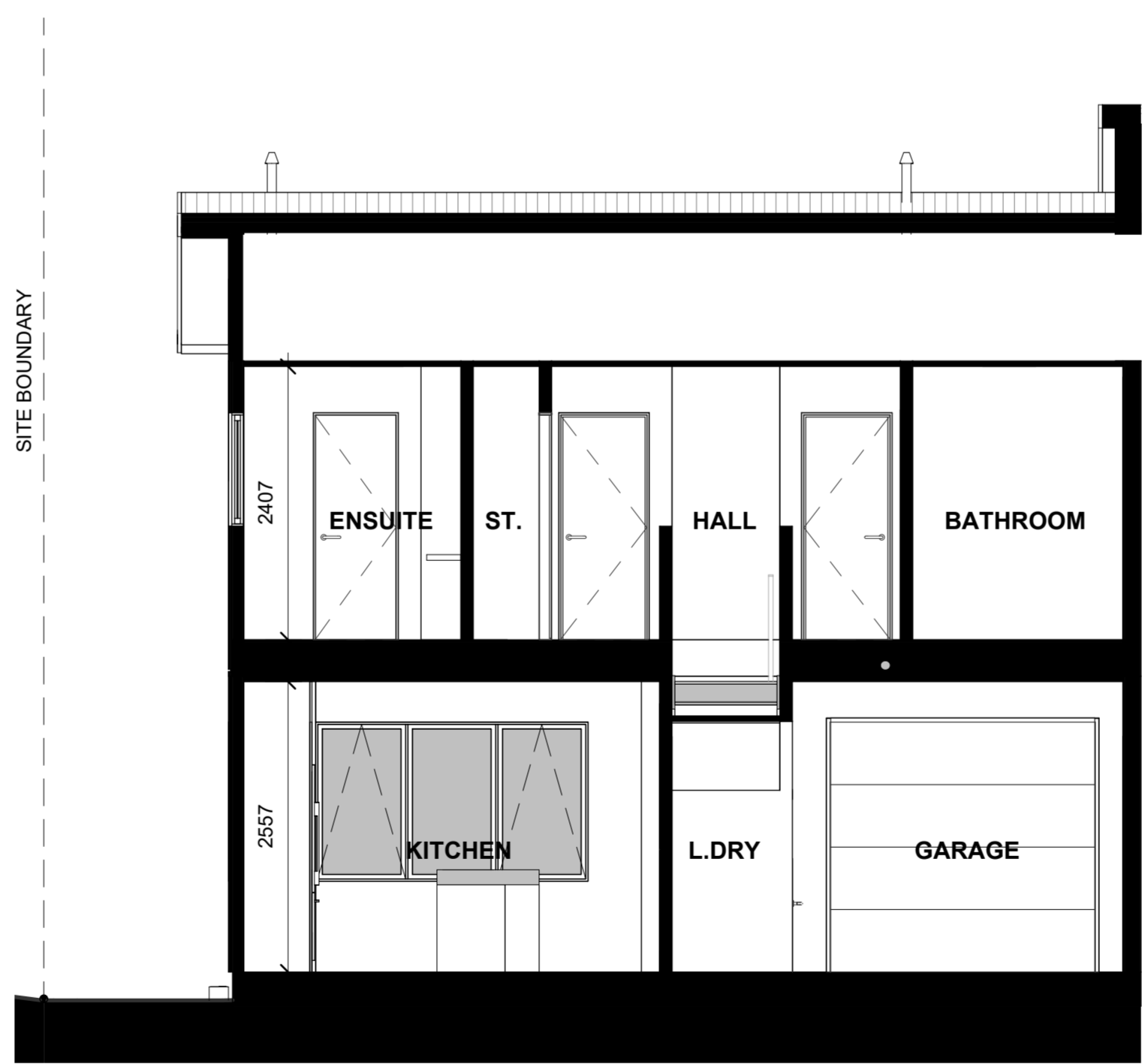

LOT 77 - SECTION B-B

LOT 77

107 KATIKATI DRIVE, MANUREWA

PLANS MAY BE SUBJECT TO CHANGE.
FLOOR AREAS INDICATED IS APPROXIMATE ONLY

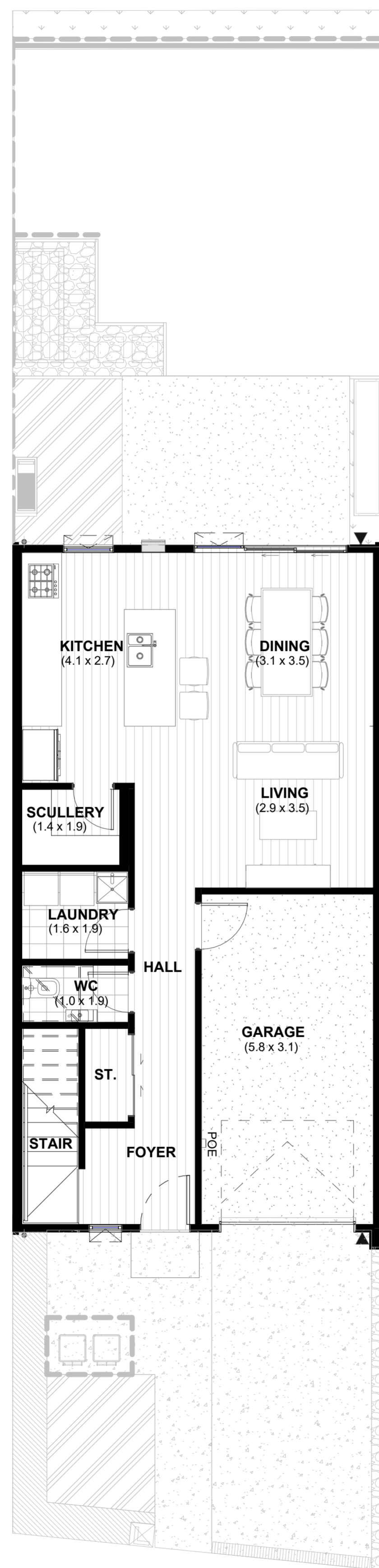

LOT 78 - GROUND FLOOR PLAN

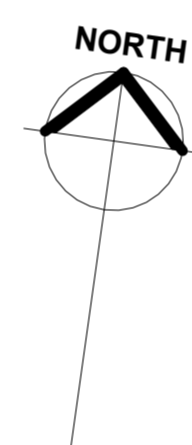

LOT 78

105 KATIKATI DRIVE, MANUREWA

First Floor Area - 78m²
Ground Floor Area - 78m²
Overall Area - 156m²
Site Area - 177m²

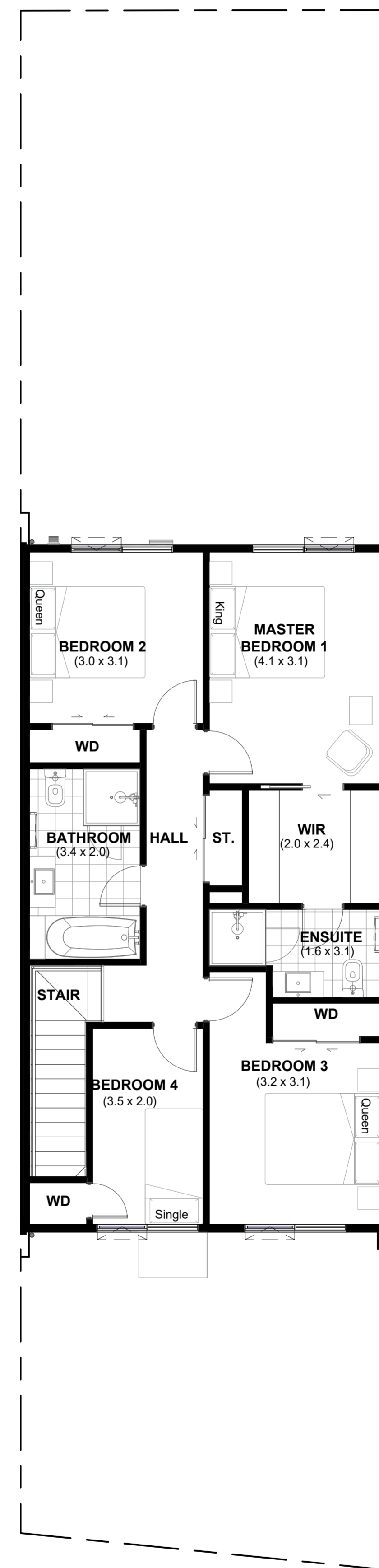
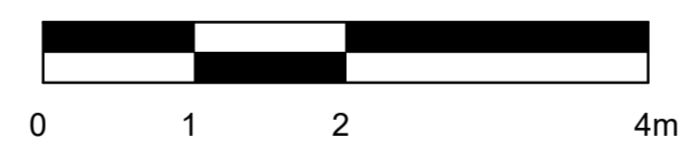

LOT 78 - FIRST FLOOR PLAN

PLANS MAY BE SUBJECT TO CHANGE.
 FLOOR AREAS INDICATED IS APPROXIMATE ONLY

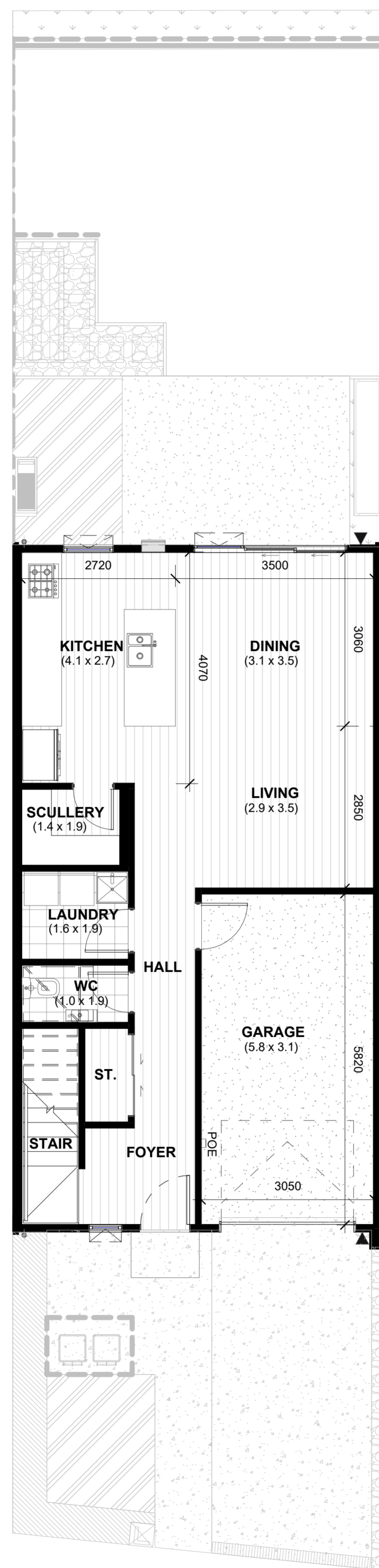

LOT 78 - GROUND FLOOR DIMENSION PLAN

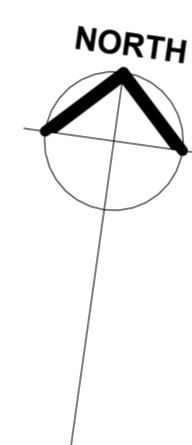

LOT 78

105 KATIKATI DRIVE, MANUREWA

First Floor Area - 78m²
Ground Floor Area - 78m²
Overall Area - 156m²
Site Area - 177m²

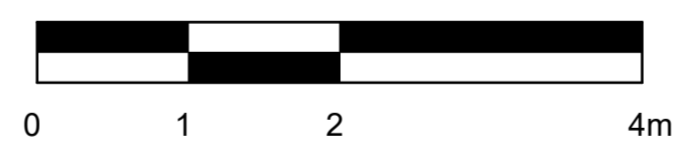

PLANS MAY BE SUBJECT TO CHANGE.
 FLOOR AREAS INDICATED IS APPROXIMATE ONLY

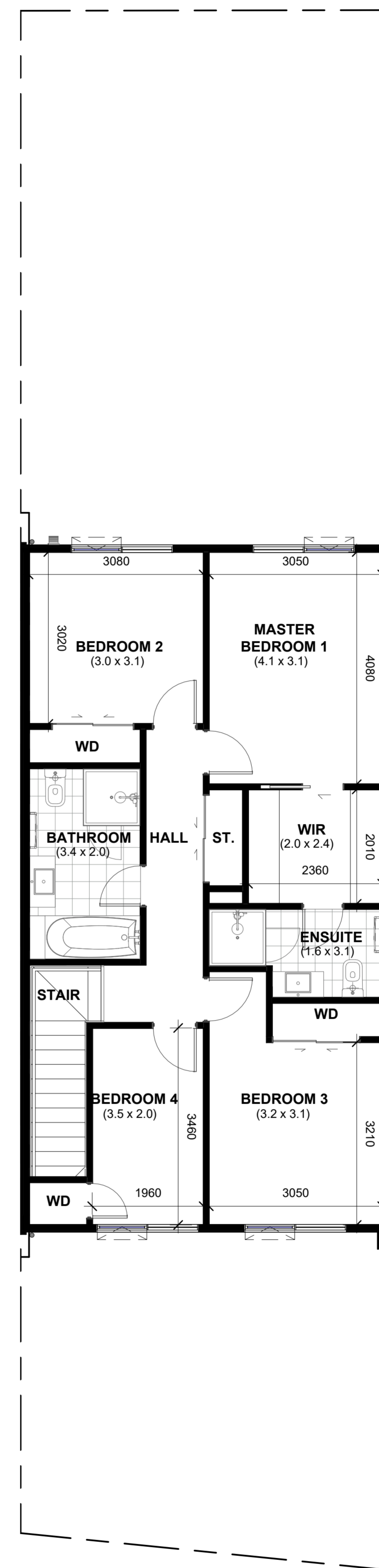

LOT 78 - FIRST FLOOR DIMENSION PLAN

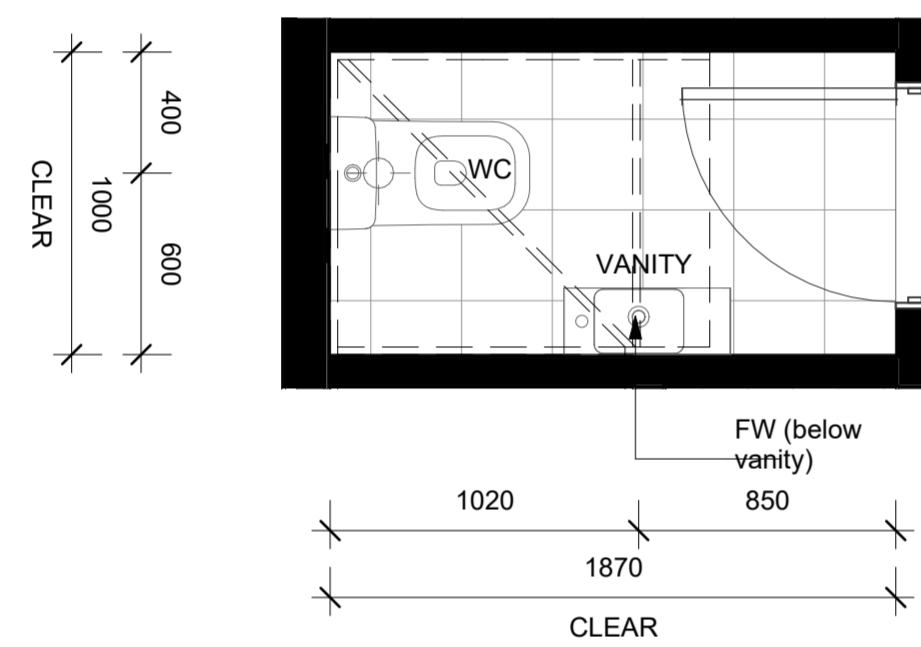

LOT 78 - GROUND FLOOR WC LAYOUT

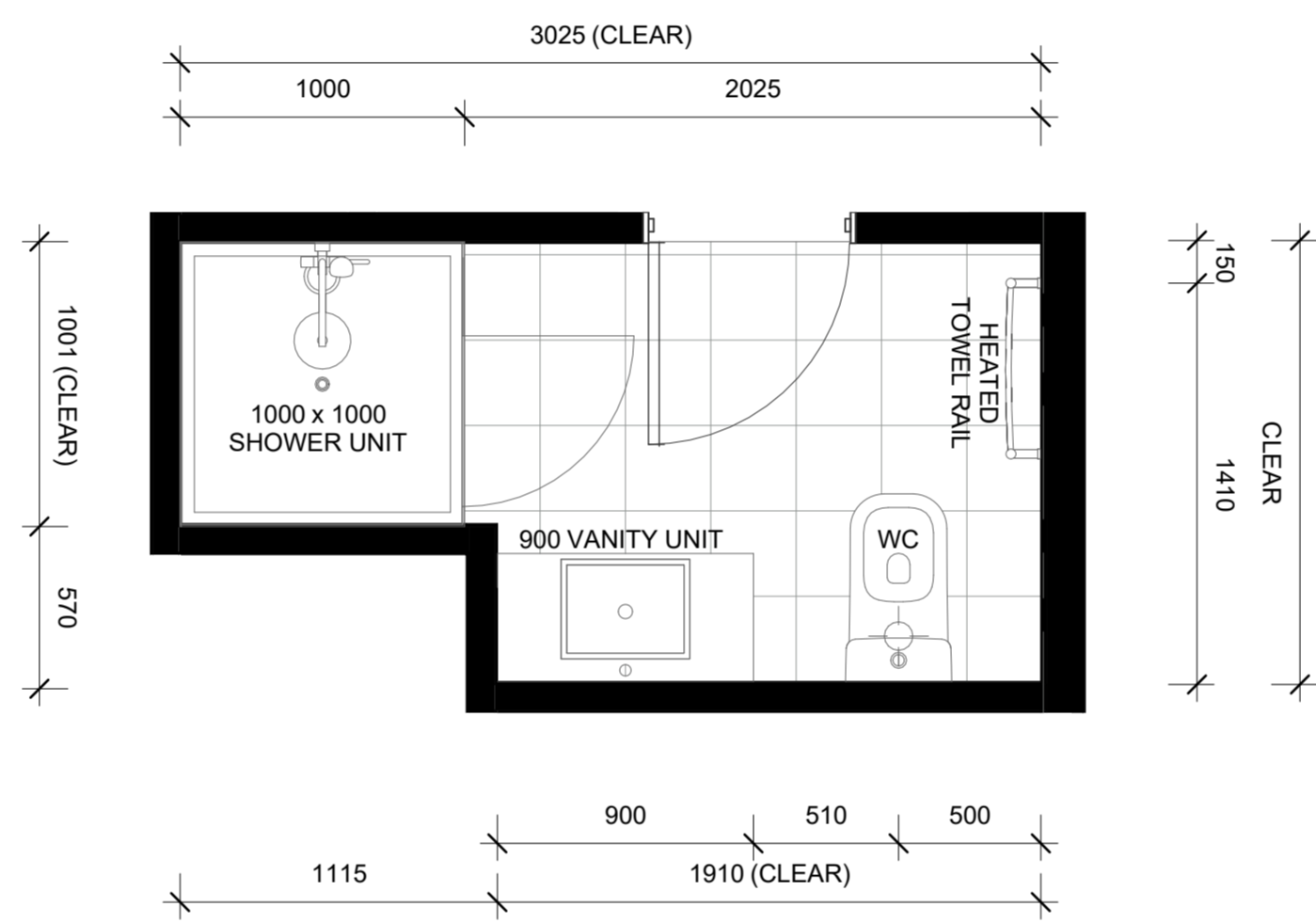

LOT 78 - FIRST FLOOR ENSUITE LAYOUT

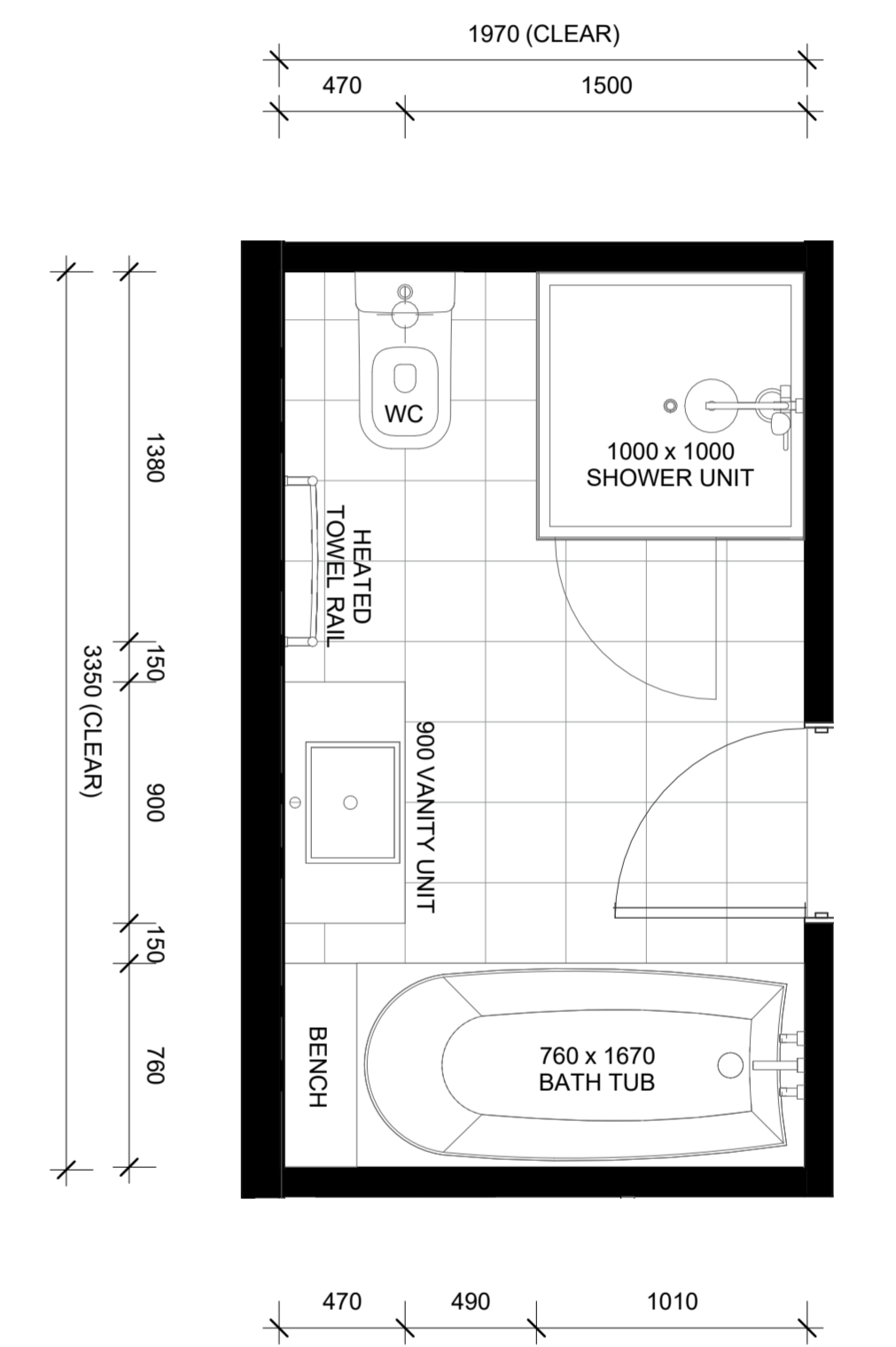

LOT 78 - FIRST FLOOR BATHROOM LAYOUT

LOT 78

105 KATIKATI DRIVE, MANUREWA

PLANS MAY BE SUBJECT TO CHANGE.
FLOOR AREAS INDICATED IS APPROXIMATE ONLY

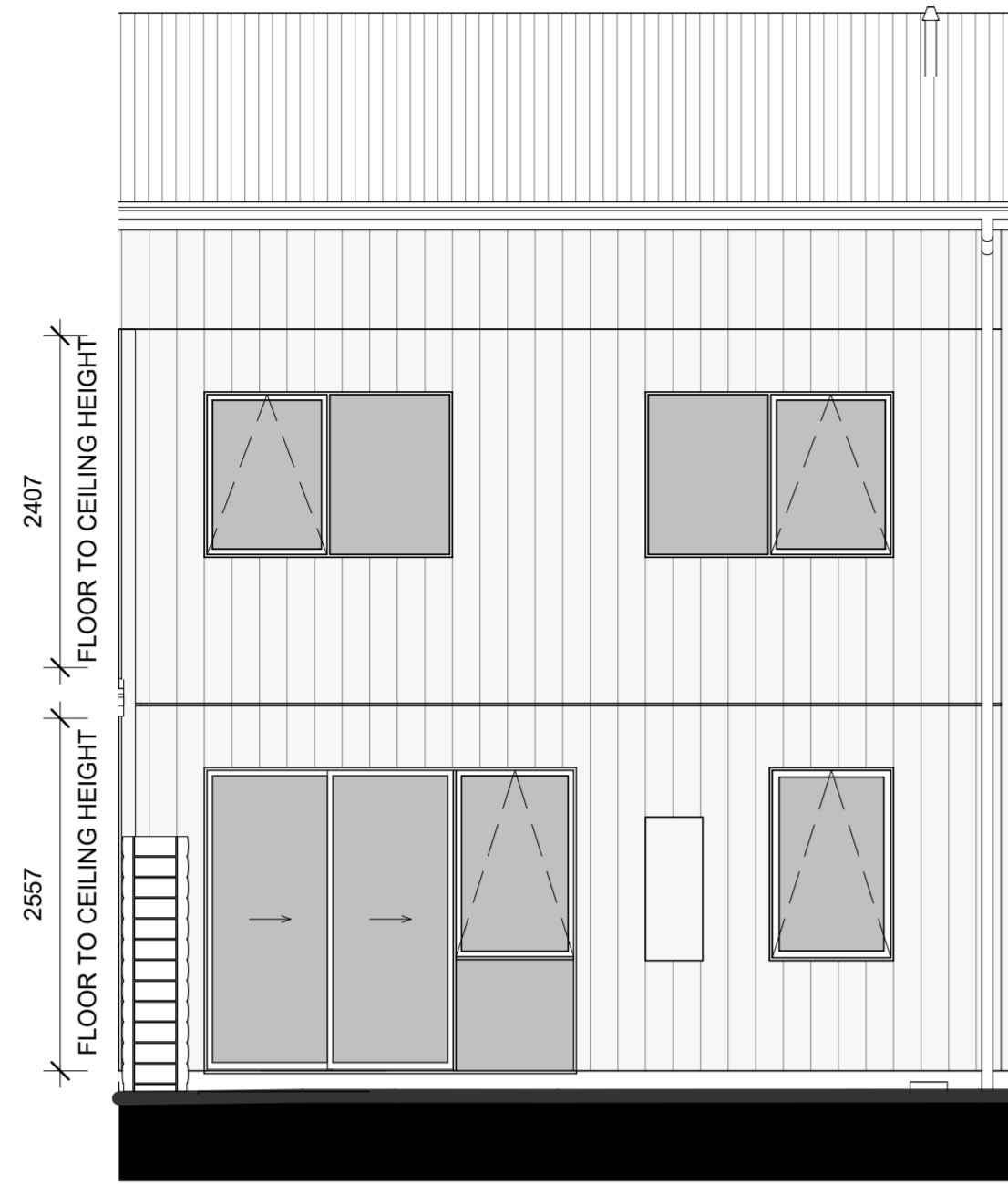

LOT 78 - NORTH ELEVATION

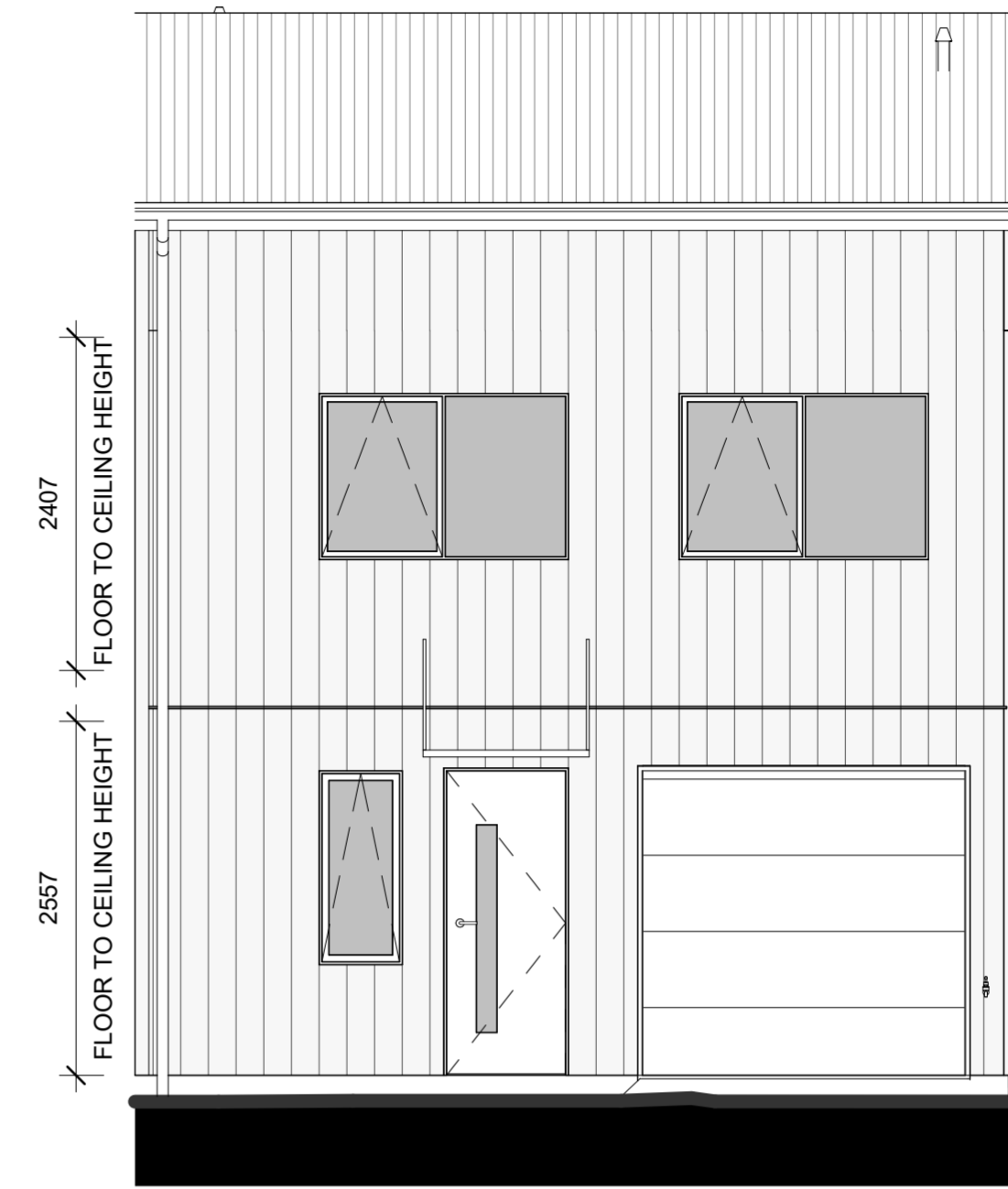

LOT 78 - SOUTH ELEVATION

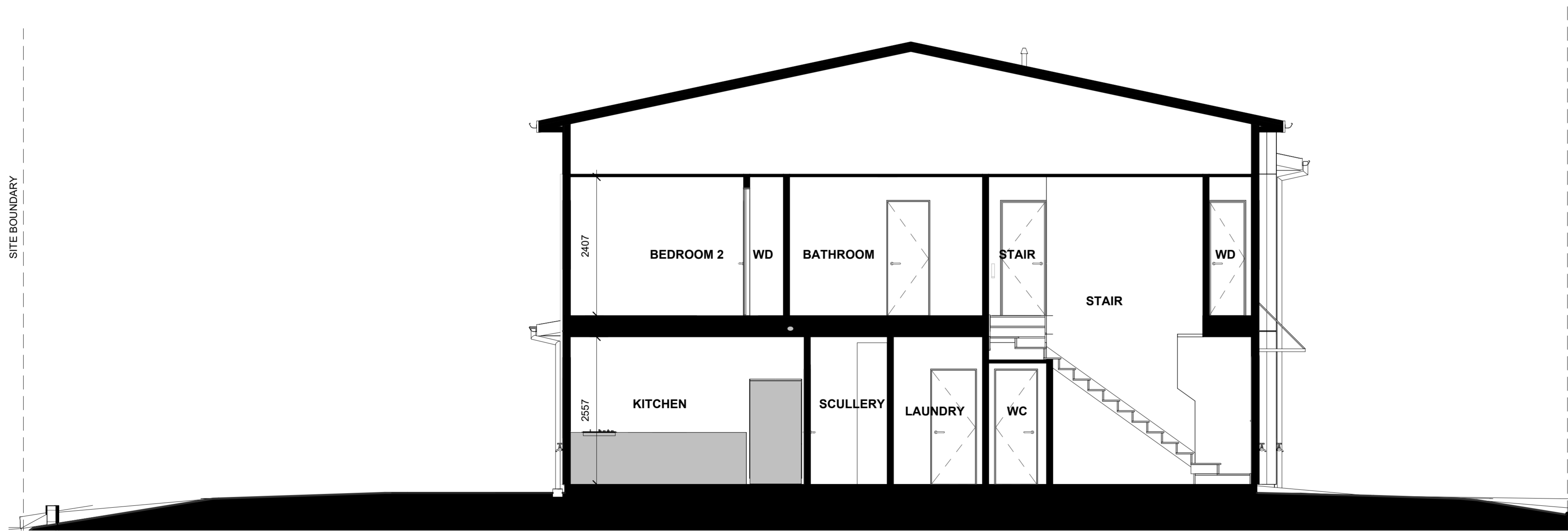

LOT 78 - SECTION A-A



LOT 78 - SECTION B-B

LOT 78

105 KATIKATI DRIVE, MANUREWA

PLANS MAY BE SUBJECT TO CHANGE.
FLOOR AREAS INDICATED IS APPROXIMATE ONLY

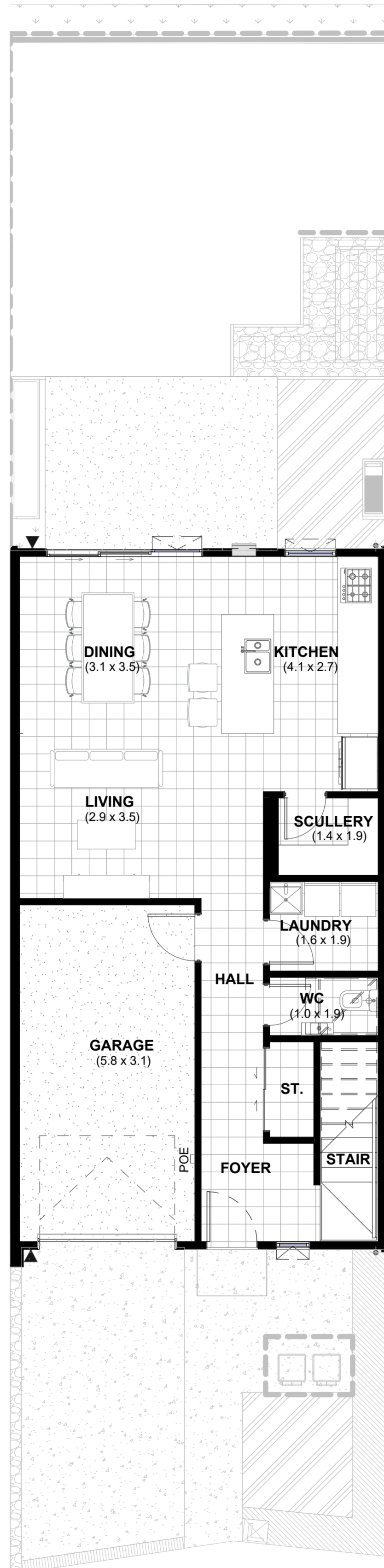

LOT 79 - GROUND FLOOR PLAN

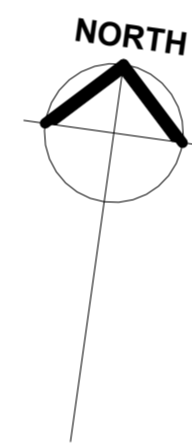

LOT 79

103 KATIKATI DRIVE, MANUREWA

First Floor Area - 78m²
Ground Floor Area - 78m²
Overall Area - 156m²
Site Area - 174m²

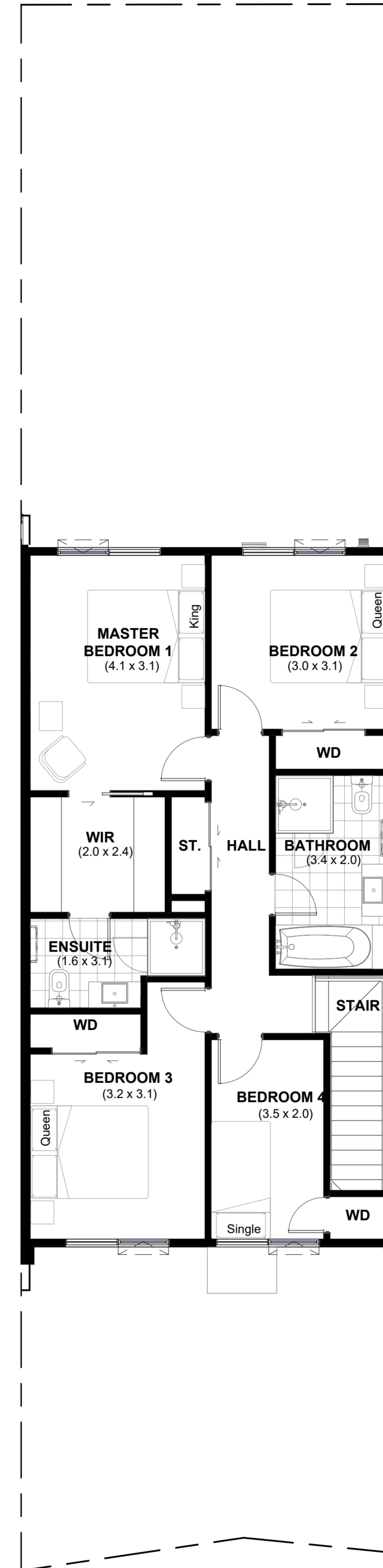
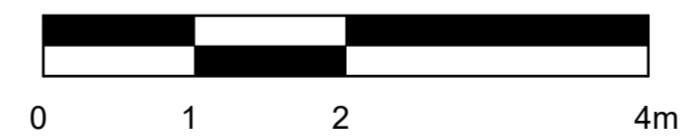

LOT 79 - FIRST FLOOR PLAN

PLANS MAY BE SUBJECT TO CHANGE.
 FLOOR AREAS INDICATED IS APPROXIMATE ONLY

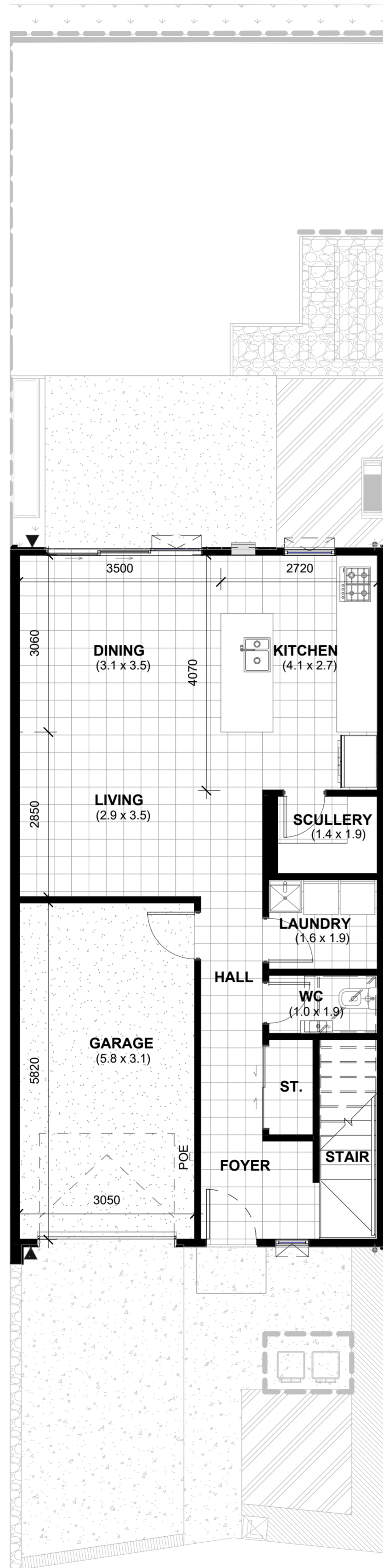

LOT 79 - GROUND FLOOR DIMENSION PLAN

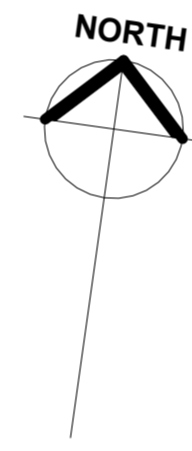

LOT 79

103 KATIKATI DRIVE, MANUREWA

First Floor Area - 78m²
Ground Floor Area - 78m²
Overall Area - 156m²
Site Area - 174m²

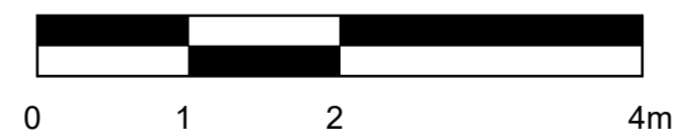

PLANS MAY BE SUBJECT TO CHANGE.
 FLOOR AREAS INDICATED IS APPROXIMATE ONLY



LOT 79 - FIRST FLOOR DIMENSION PLAN

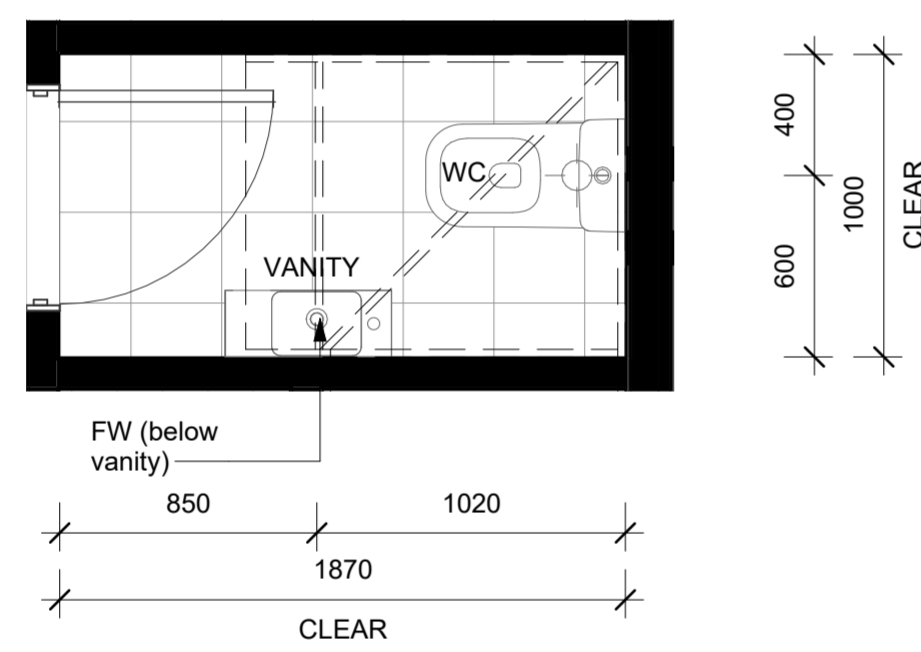

LOT 79 - GROUND FLOOR WC LAYOUT

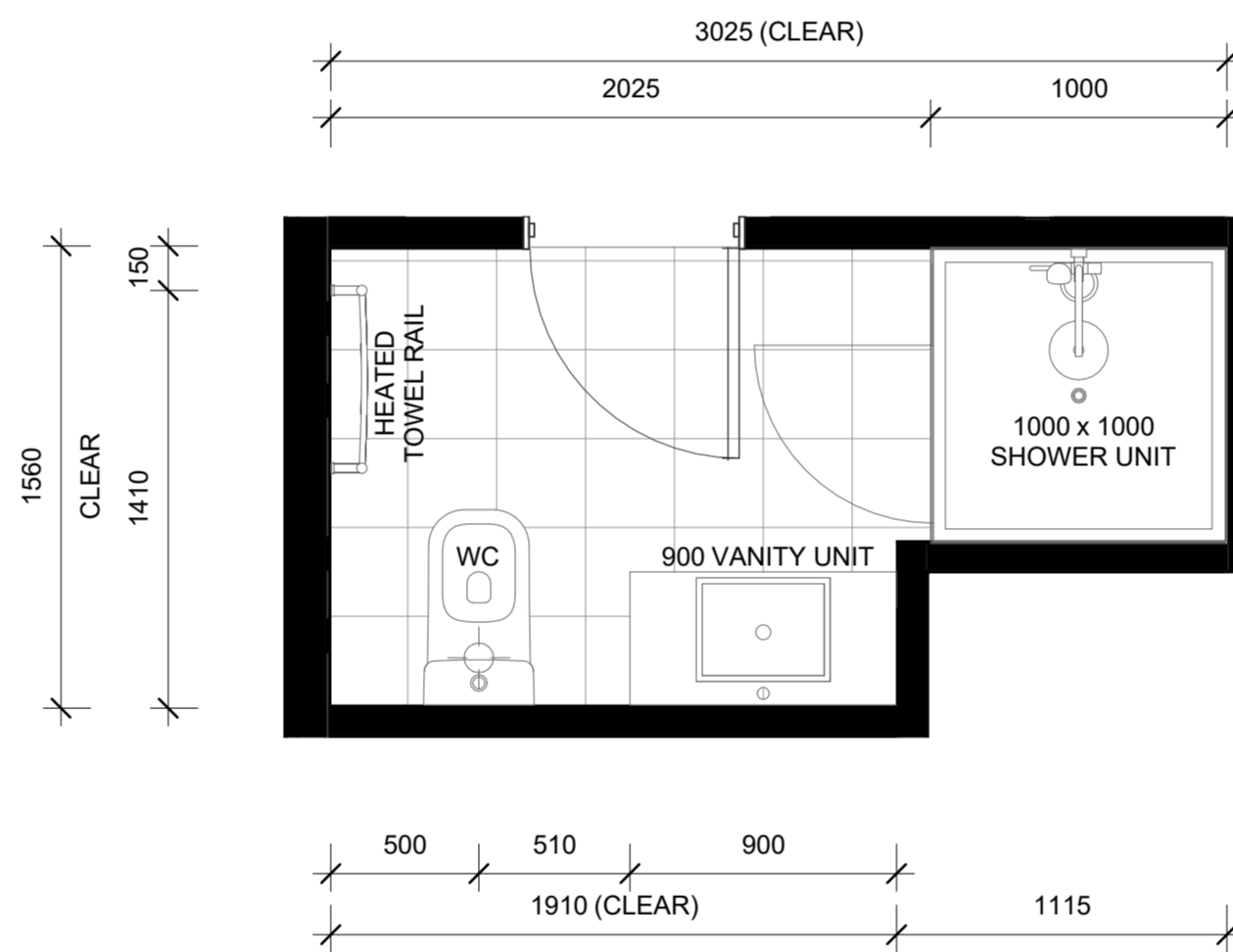

LOT 79 - FIRST FLOOR ENSUITE LAYOUT

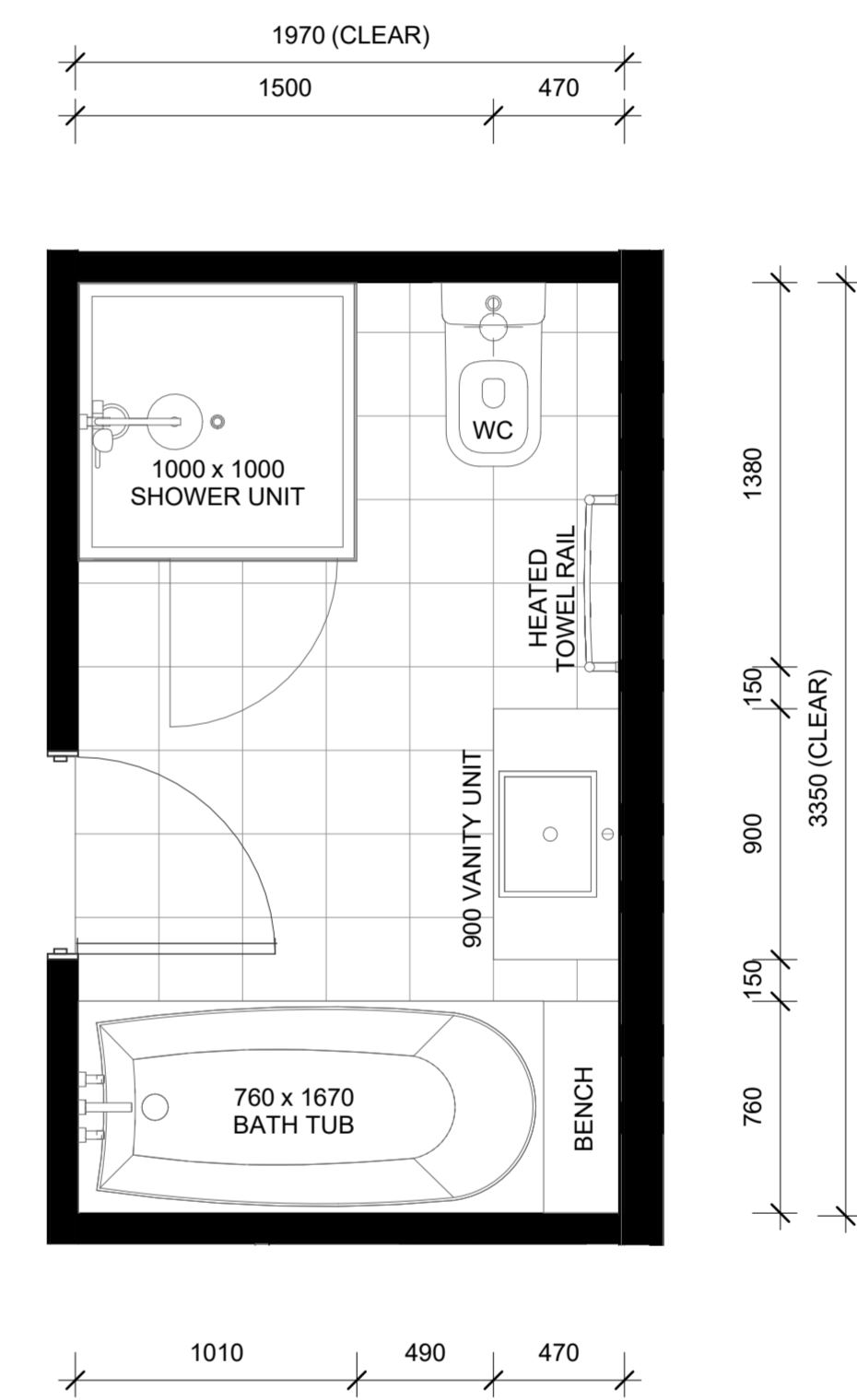

LOT 79 - FIRST FLOOR BATHROOM LAYOUT

LOT 79

103 KATIKATI DRIVE, MANUREWA

PLANS MAY BE SUBJECT TO CHANGE.
FLOOR AREAS INDICATED IS APPROXIMATE ONLY

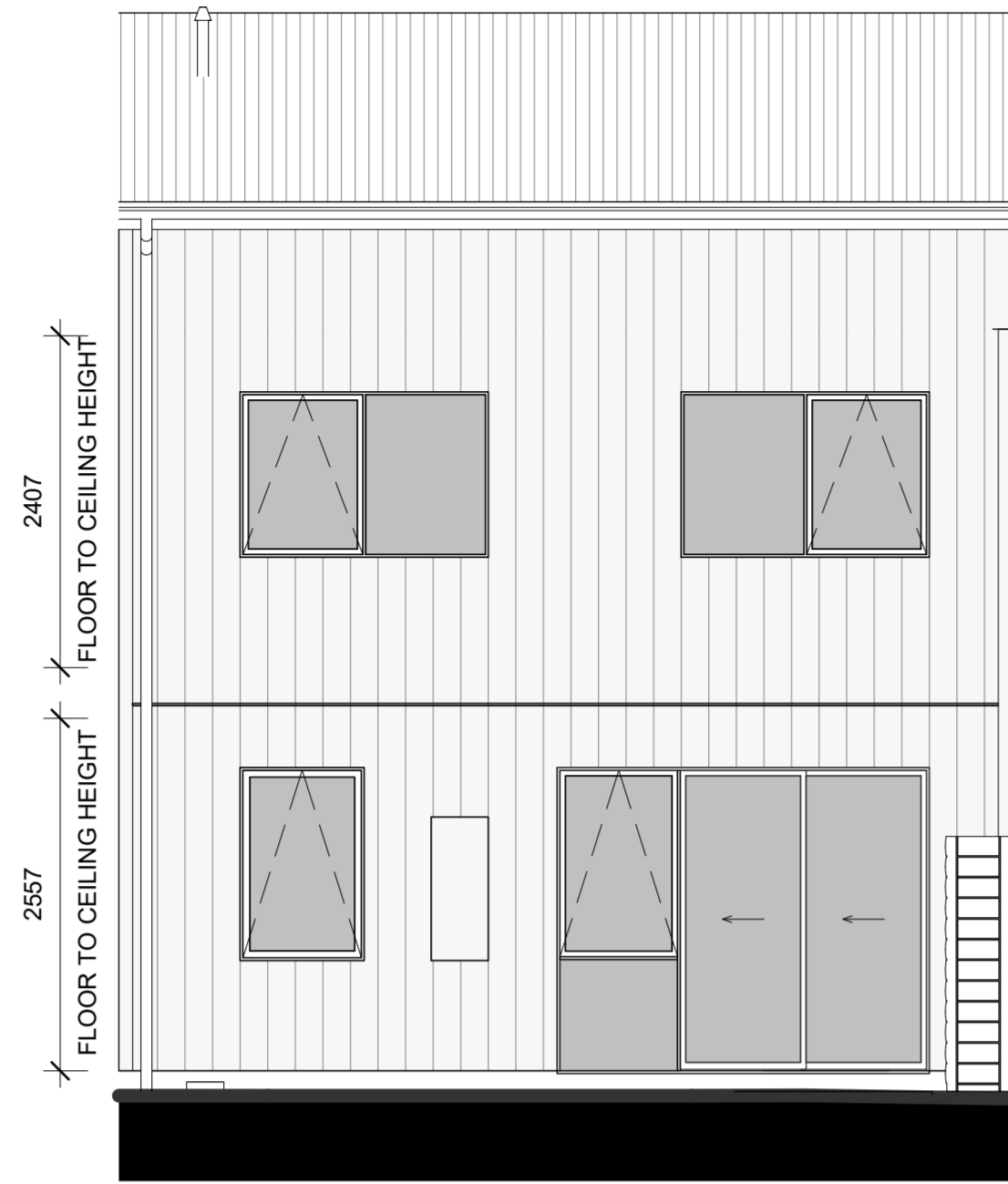

LOT 79 - NORTH ELEVATION

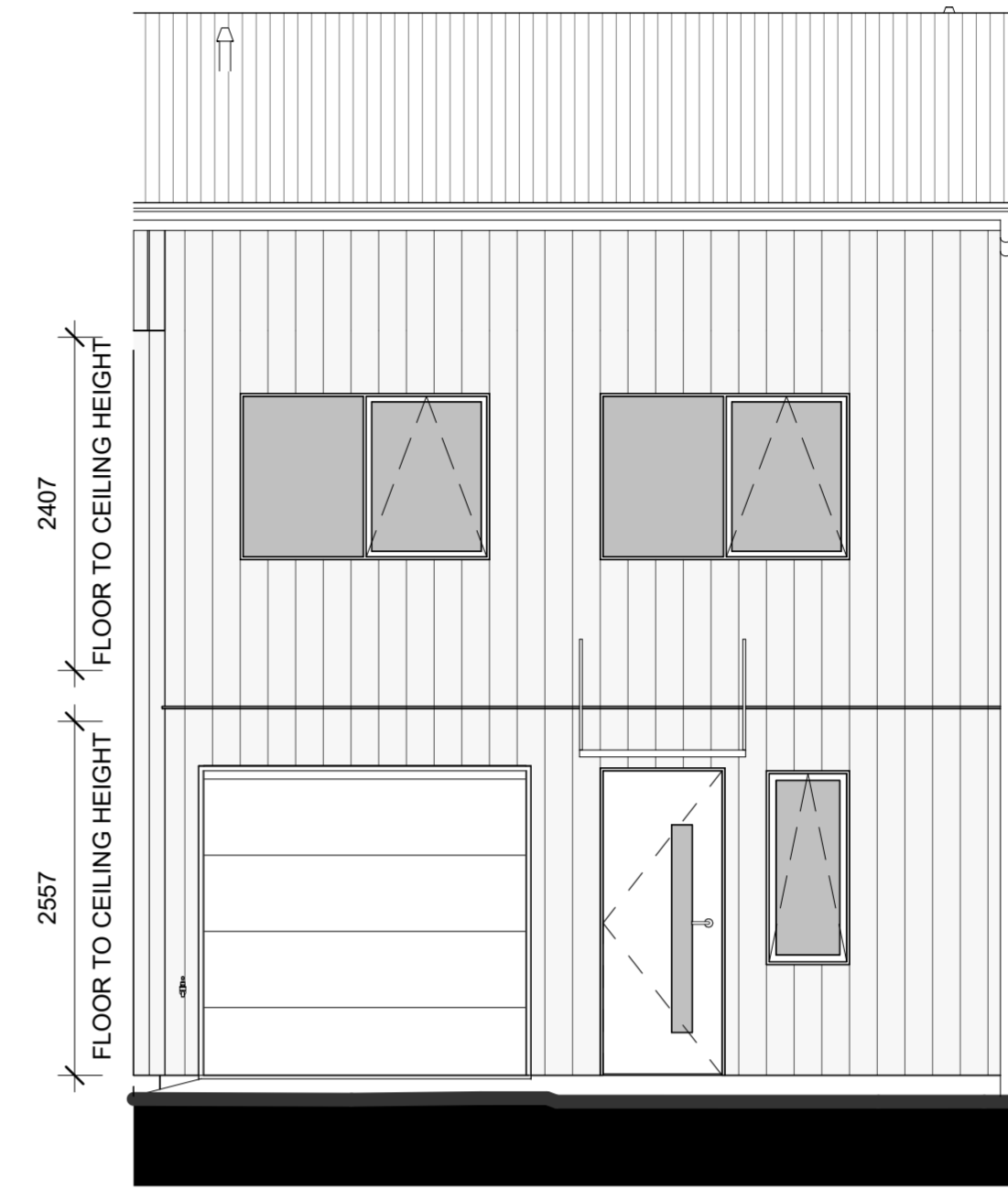

LOT 79 - SOUTH ELEVATION

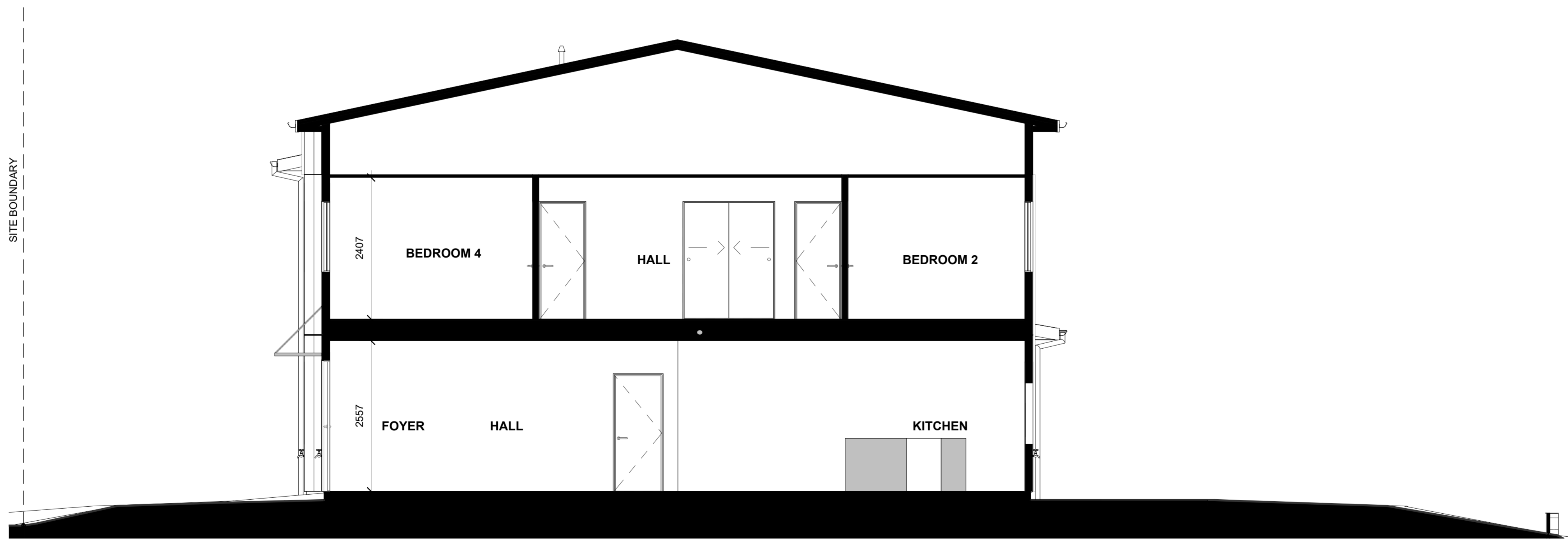

LOT 79 - SECTION A-A

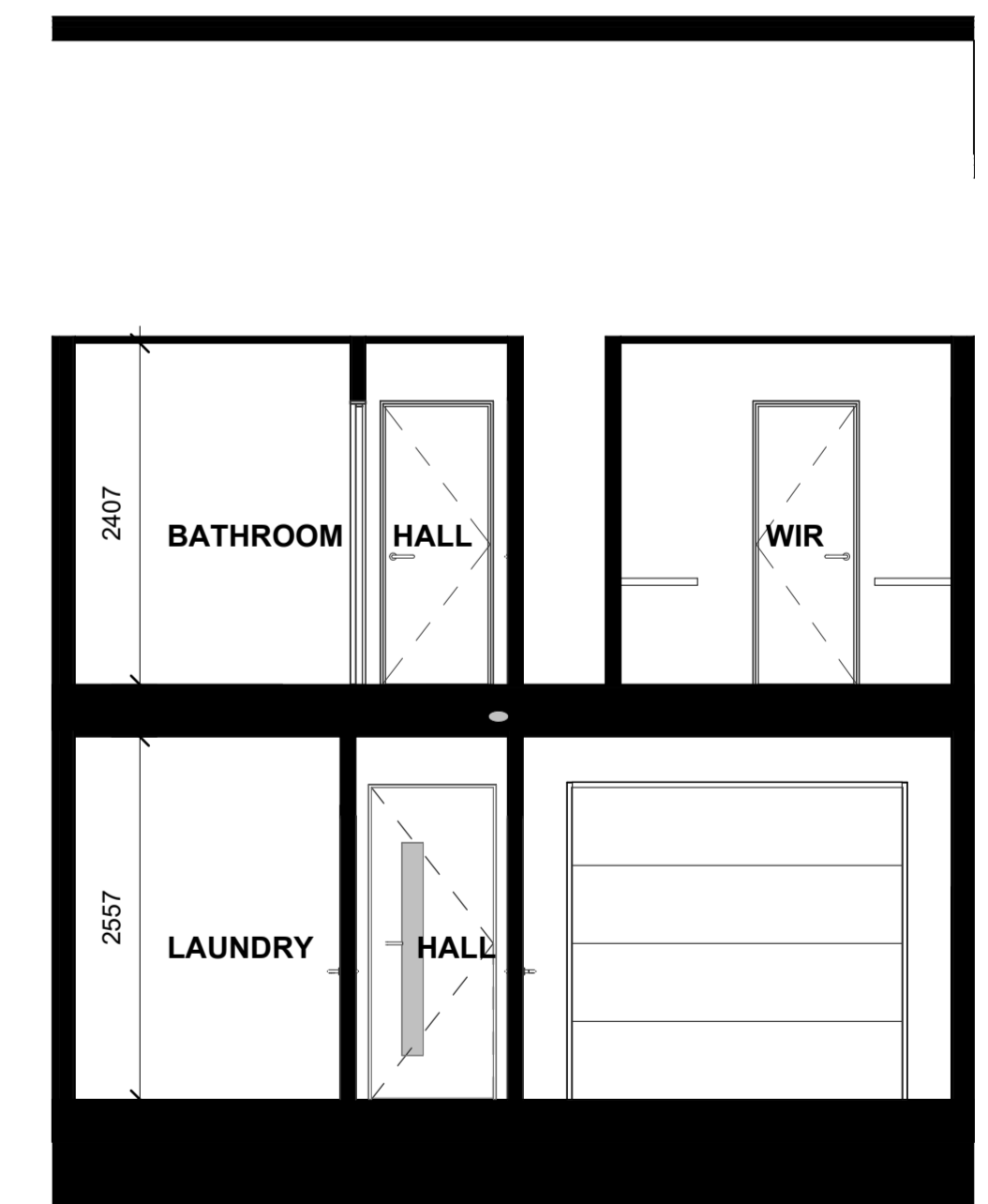

LOT 79 - SECTION B-B

LOT 79

103 KATIKATI DRIVE, MANUREWA

PLANS MAY BE SUBJECT TO CHANGE.
FLOOR AREAS INDICATED IS APPROXIMATE ONLY

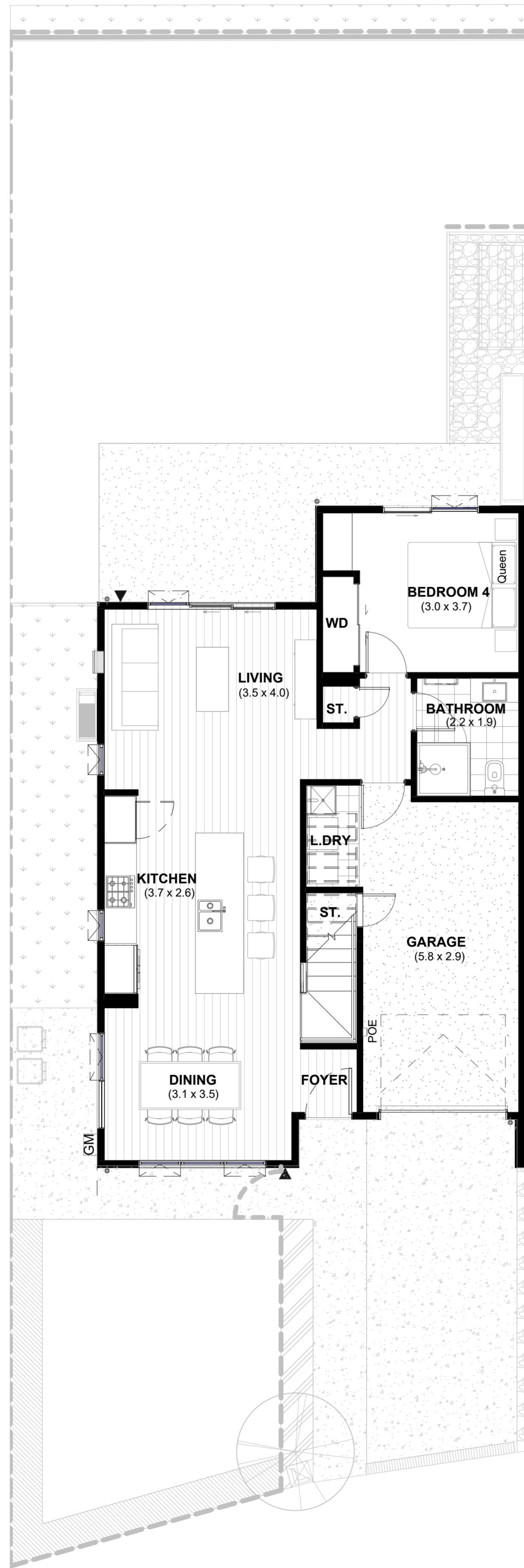

LOT 80 - GROUND FLOOR PLAN

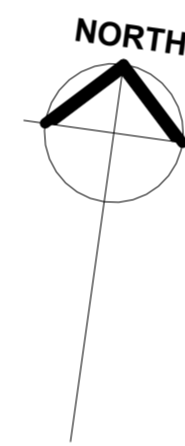

LOT 80

101 KATIKATI DRIVE, MANUREWA

First Floor Area - 81m²
Ground Floor Area - 87m²
Overall Area - 168m²
Site Area - 269m²

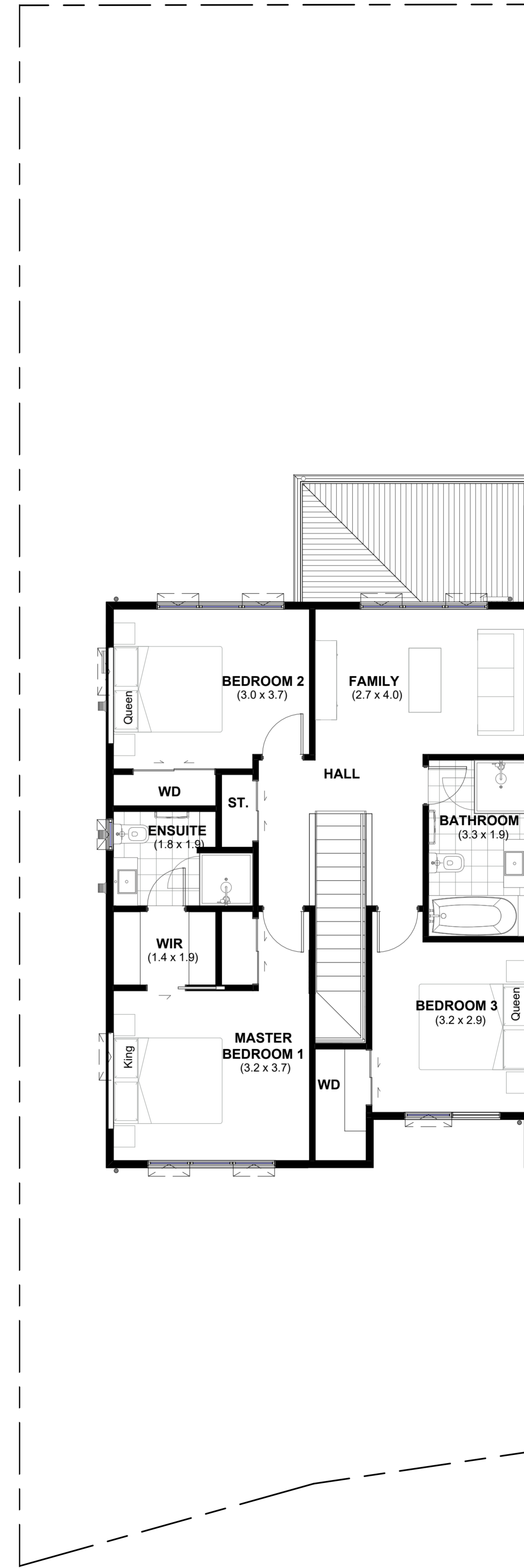
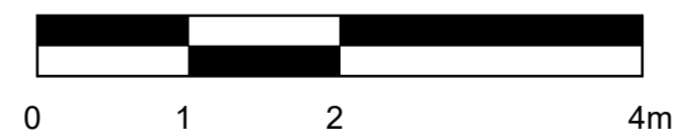

LOT 80 - FIRST FLOOR PLAN

PLANS MAY BE SUBJECT TO CHANGE.
 FLOOR AREAS INDICATED IS APPROXIMATE ONLY

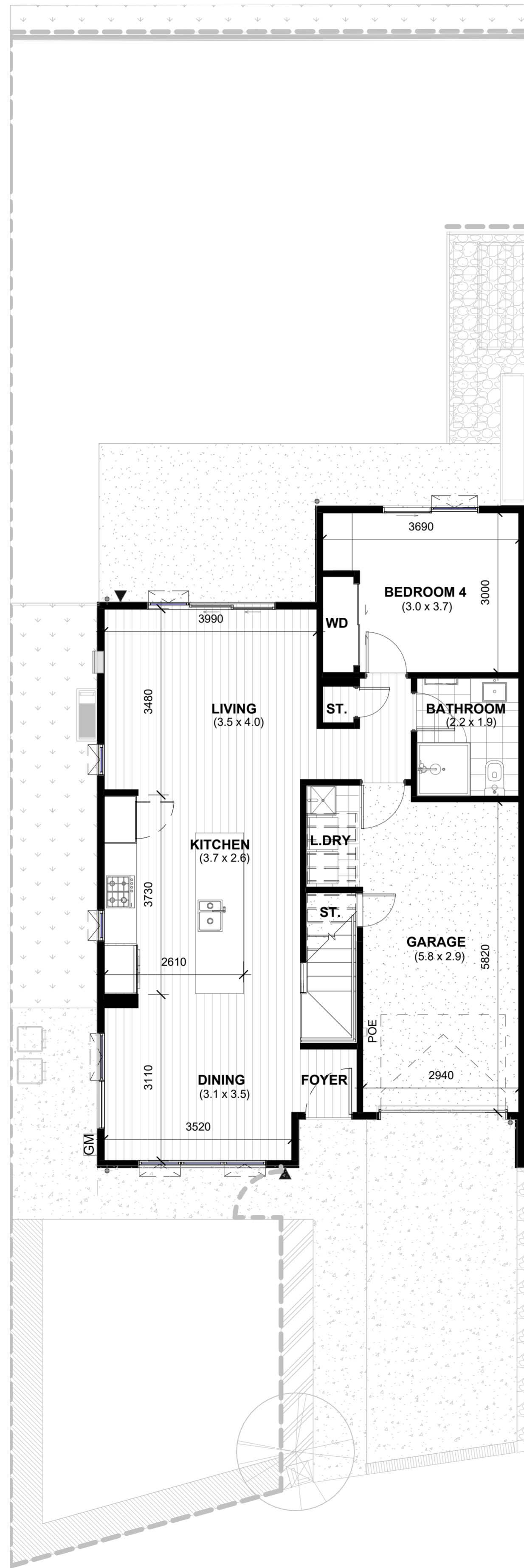

LOT 80 - GROUND FLOOR DIMENSION PLAN

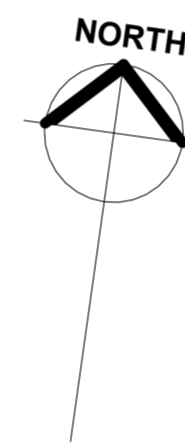

LOT 80

101 KATIKATI DRIVE, MANUREWA

First Floor Area - 81m²
Ground Floor Area - 87m²
Overall Area - 168m²
Site Area - 269m²

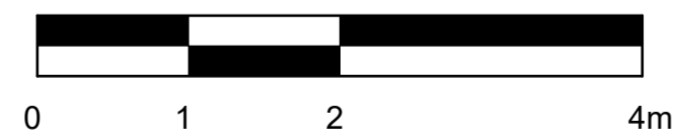

PLANS MAY BE SUBJECT TO CHANGE.
 FLOOR AREAS INDICATED IS APPROXIMATE ONLY

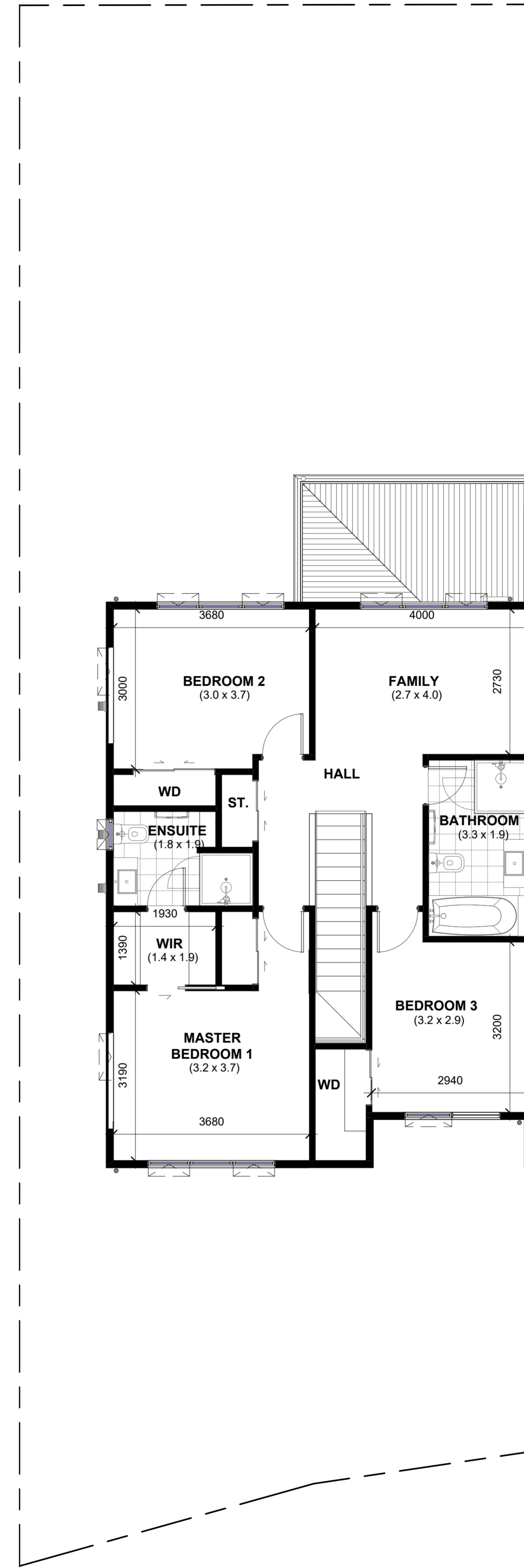

LOT 80 - FIRST FLOOR DIMENSION PLAN

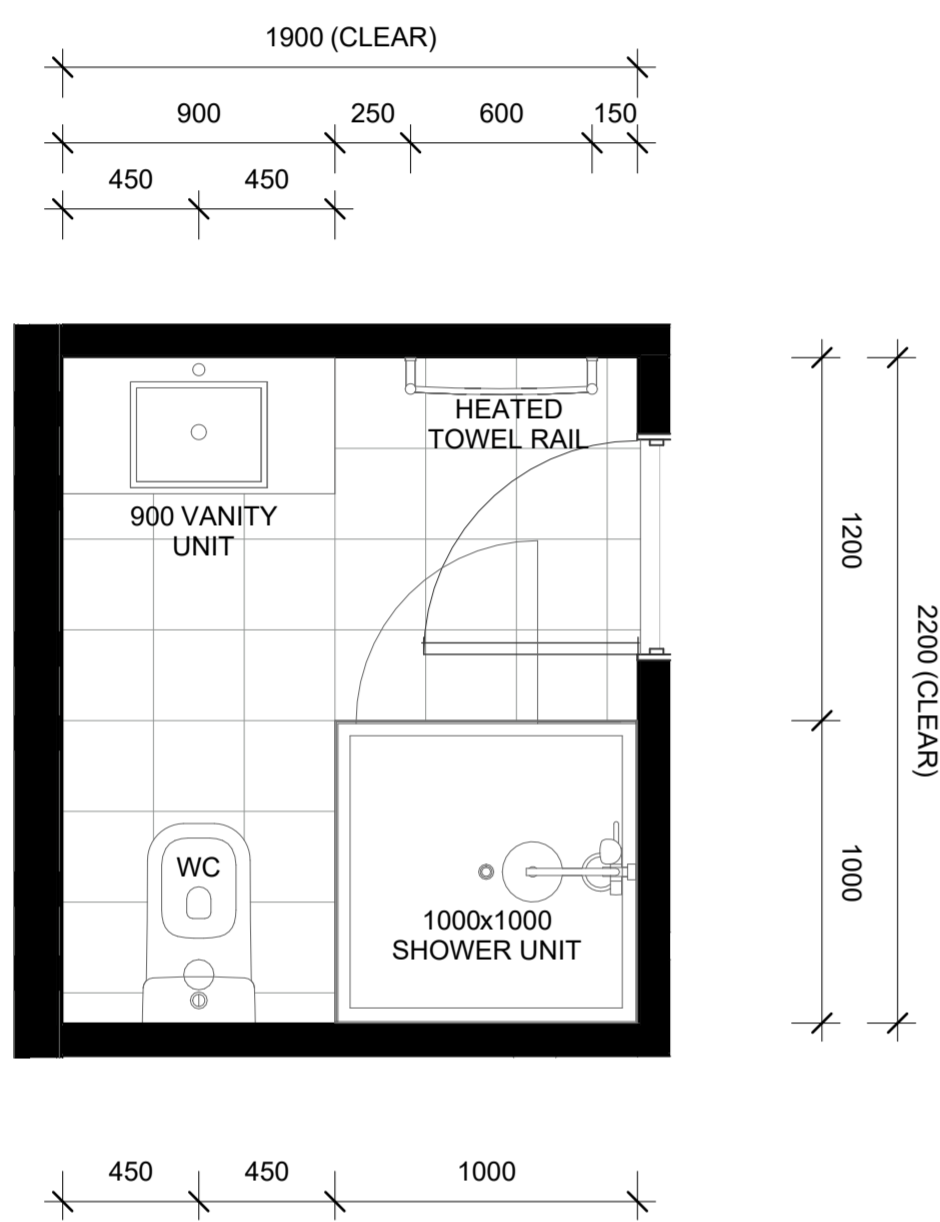

LOT 80 - GROUND FLOOR BATHROOM LAYOUT

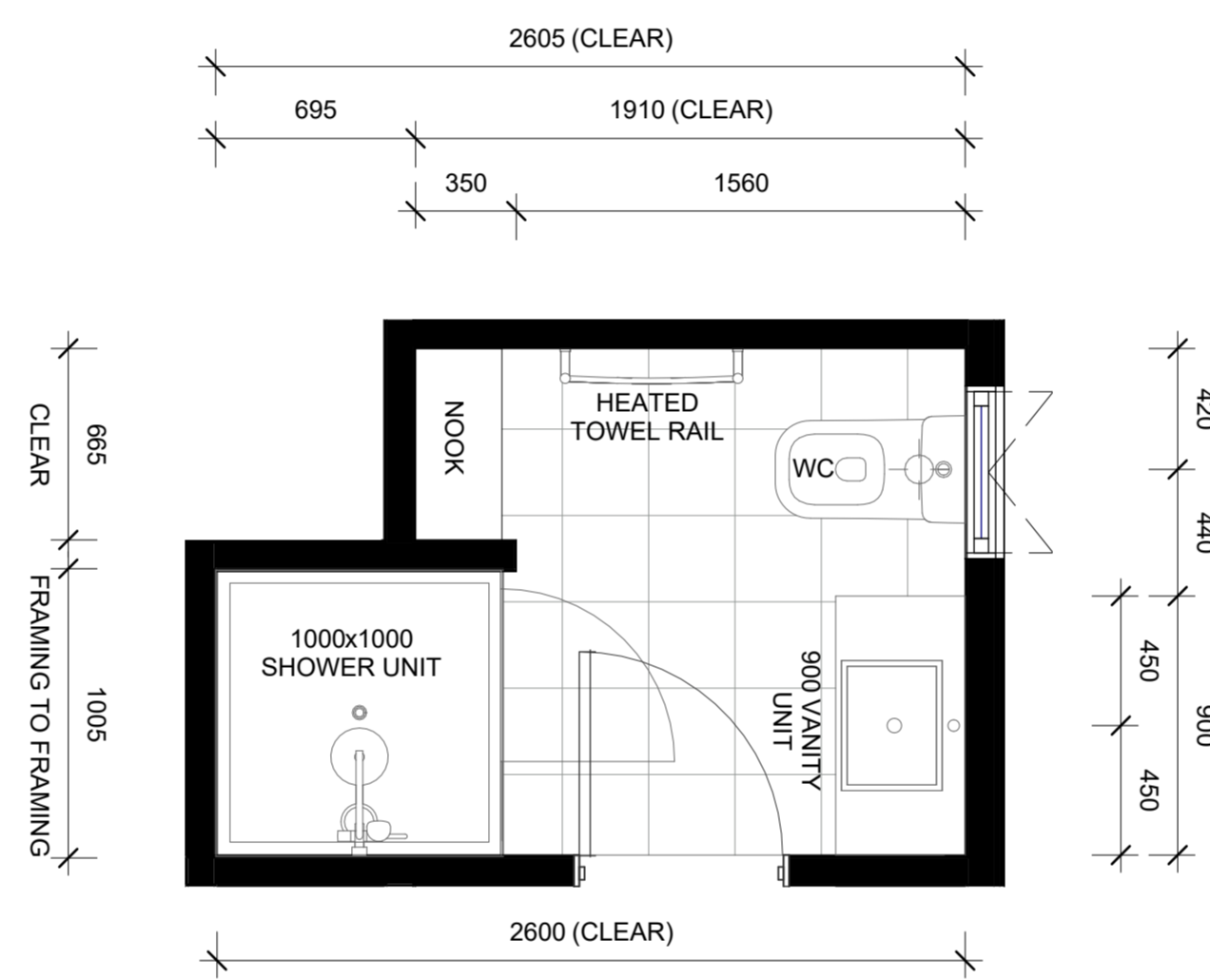

LOT 80 - FIRST FLOOR ENSUITE PLAN

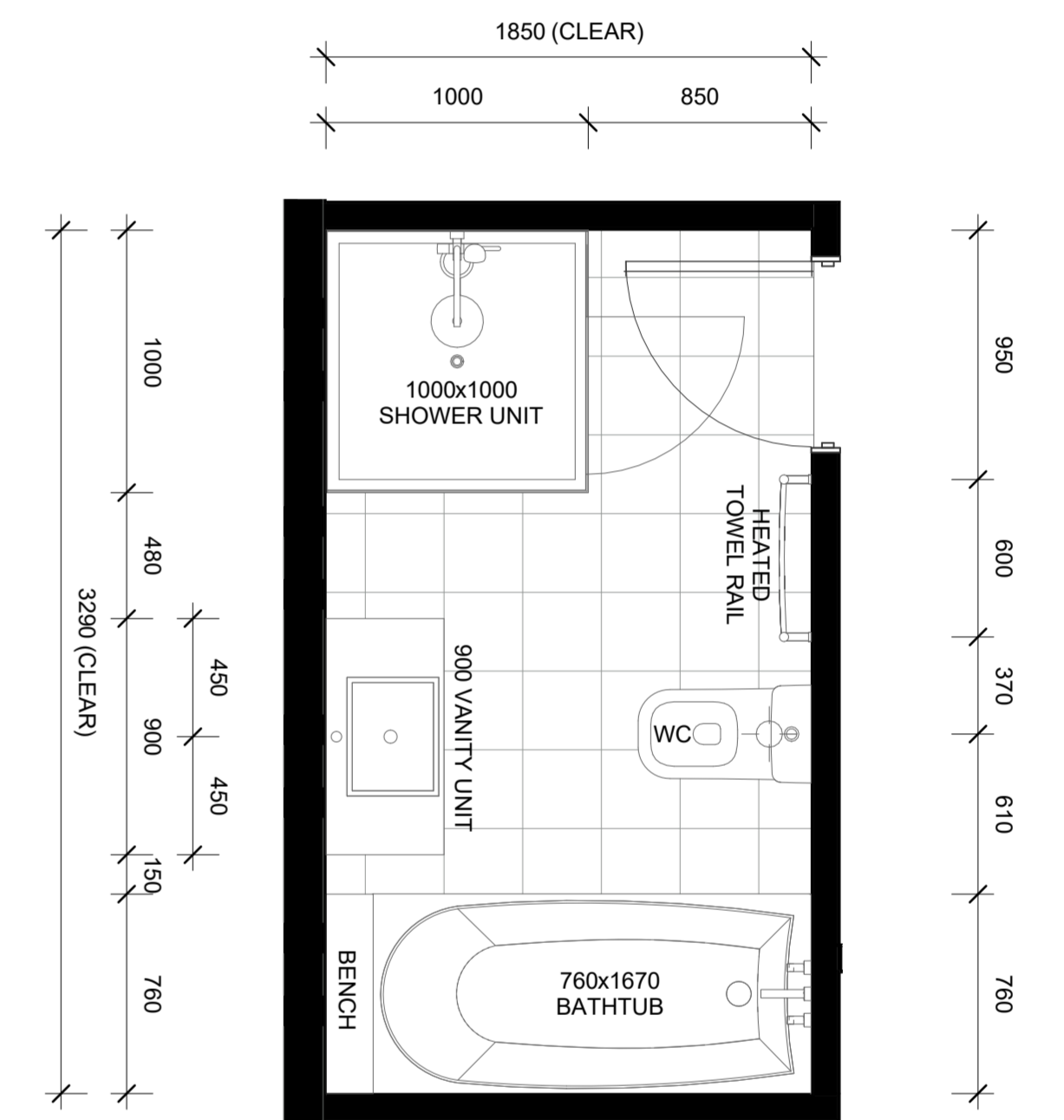

LOT 80 - FIRST FLOOR BATHROOM LAYOUT

LOT 80

101 KATIKATI DRIVE, MANUREWA

PLANS MAY BE SUBJECT TO CHANGE.
FLOOR AREAS INDICATED IS APPROXIMATE ONLY

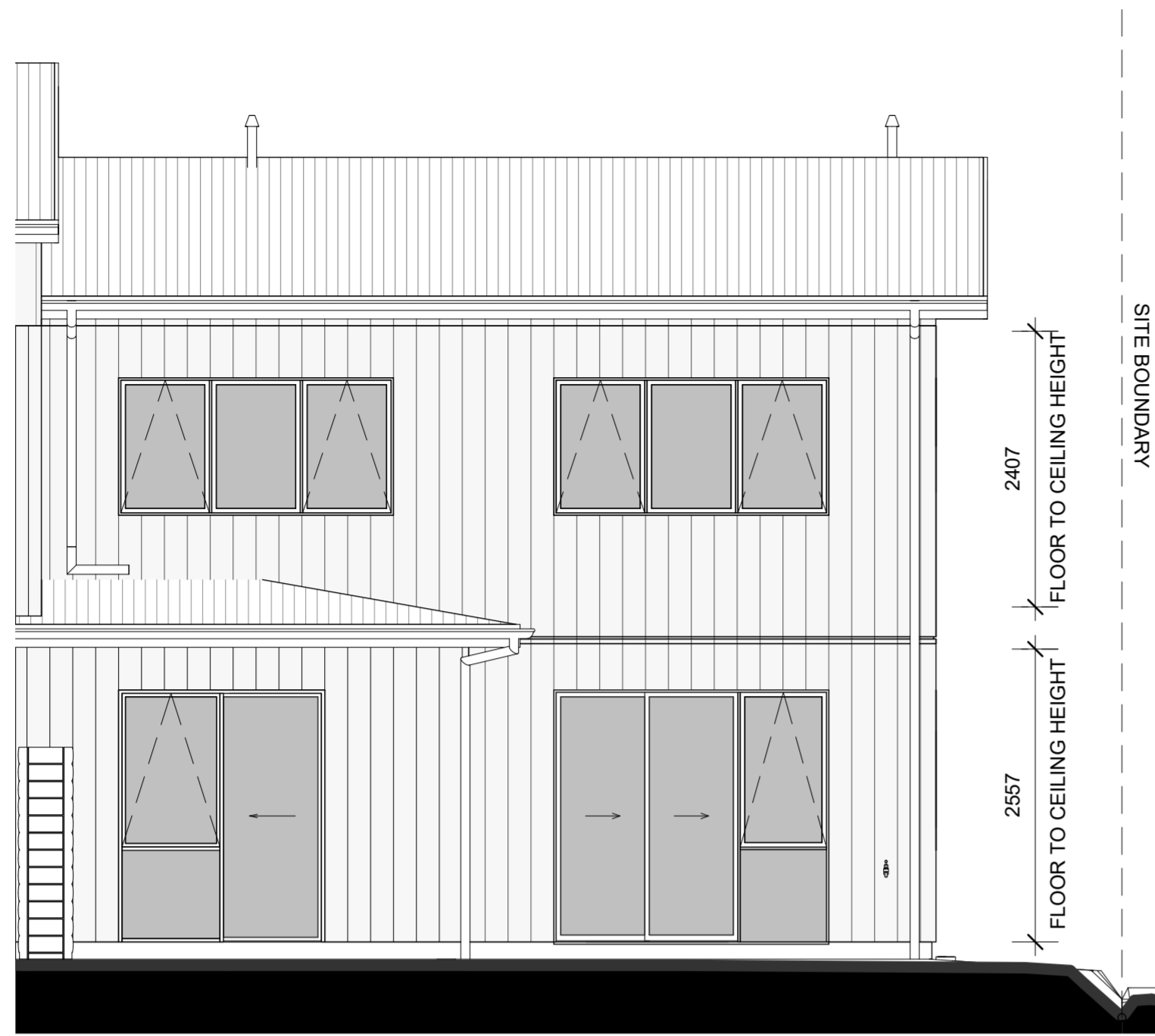

LOT 80 - NORTH ELEVATION

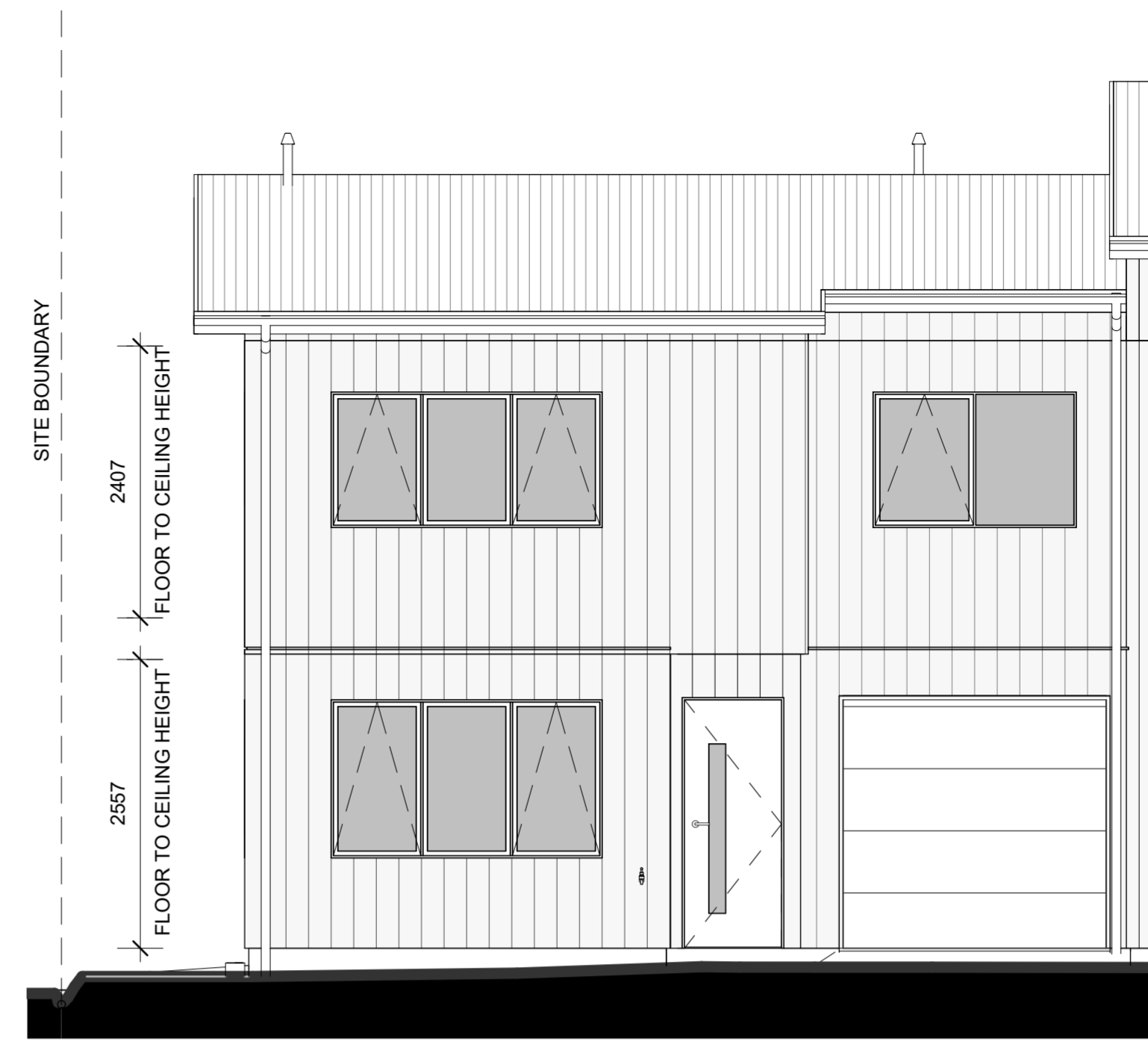

LOT 80 - SOUTH ELEVATION

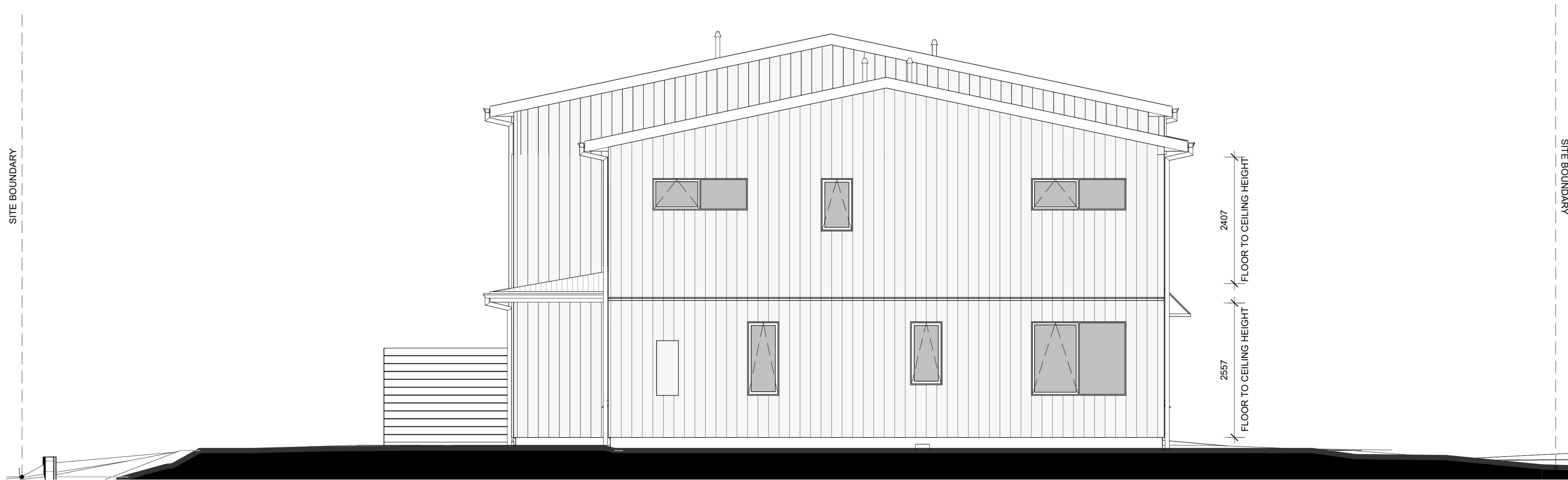

LOT 80 - WEST ELEVATION

LOT 80

101 KATIKATI DRIVE, MANUREWA

PLANS MAY BE SUBJECT TO CHANGE.
FLOOR AREAS INDICATED IS APPROXIMATE ONLY

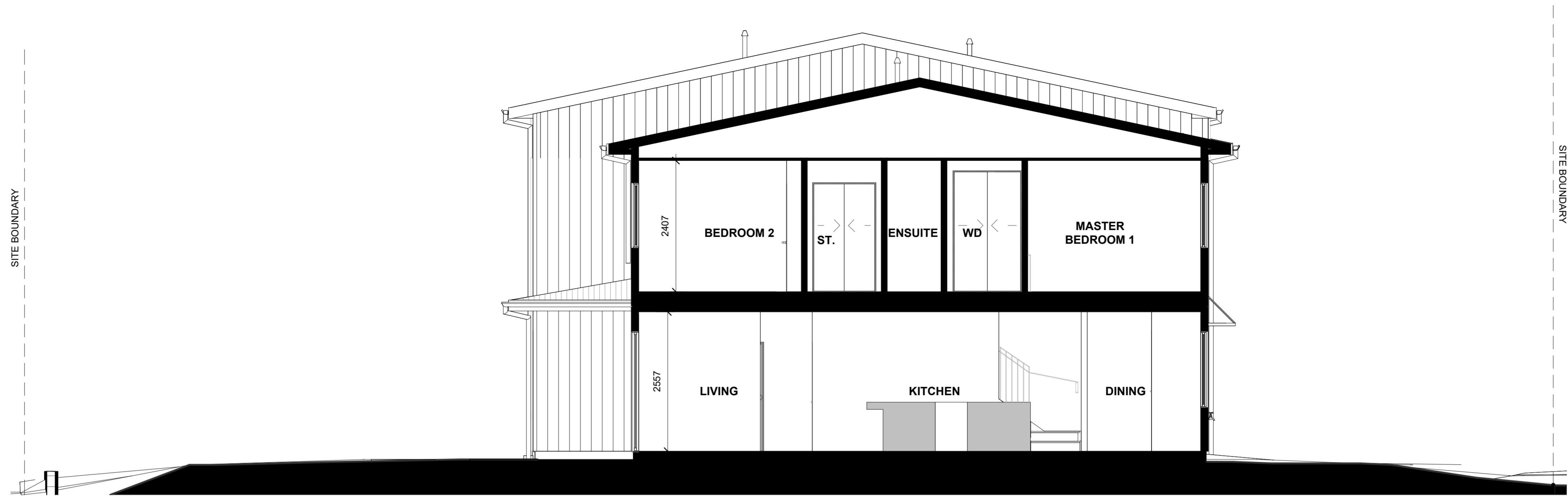

LOT 80 - SECTION A-A

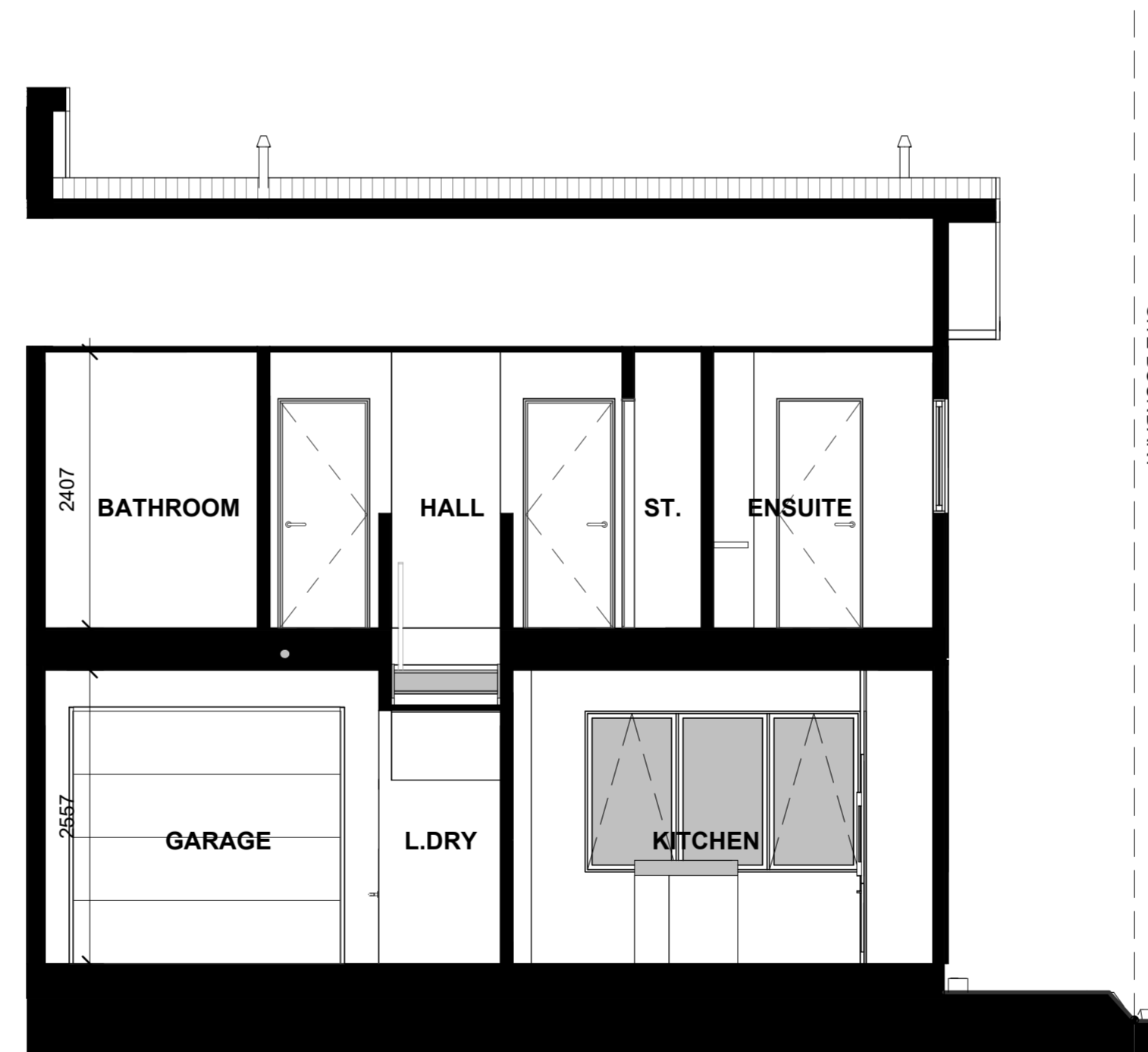

LOT 80 - SECTION B-B

LOT 80

101 KATIKATI DRIVE, MANUREWA

PLANS MAY BE SUBJECT TO CHANGE.
FLOOR AREAS INDICATED IS APPROXIMATE ONLY